



Next Ord. 4553
Next Reso. 26021

VILLAGE OF VILLA PARK
Village Hall, Board Chambers
20 South Ardmore Avenue
Villa Park, IL 60181

Village Board of Trustees

April 13, 2026

7:00 PM

Village President Kevin Patrick
Village Clerk Rolf Laukant

Village Trustees Cari Alfano, Jorge Cordova, Tina Konstatos, Jack Kozar, Deepa Kumar, Khalid Sabri

Public participation is invited. When called upon, please approach the microphone and state your name. Kindly limit your remarks to 3 minutes.

- 1. Call to Order - Roll Call**
- 2. Pledge of Allegiance**
- 3. Amendments to the Agenda**
- 4. Public Comments on Agenda Items**
- 5. Public Comments on Non-Agenda Items**
- 6. Proclamations**
 - a. Proclamation Recognizing April 2026 as Autism Awareness Month
 - b. Proclamation Declaring April 24, 2026, as Arbor Day 2026 in the Village of Villa Park, Illinois.
 - c. Proclamation Recognizing April 2026 as National Distracted Driving Awareness Month
 - d. Proclamation Recognizing April 2026 as Fair Housing Month
- 7. Presentation**
 - a. DuPage United Presentation
- 8. Appointment to Commission**
 - a. Appointment of William (Bill) Zucker as Commissioner of the Board of Fire and Police Commission for an unexpired term until 4/30/2027
 - b. Appointment of Jennifer Hamilton as Commissioner of the G.R.E.E.N. Commission.
- 9. Consent Agenda**
 - a. Bill Listings for the weeks of March 23, 2026 in the amount of \$165,278.86, March 30, 2026 in the amount of \$1,042,097.29 and April 6, 2026 in the amount of \$122,655.94.

- b. Approval of the Minutes of the Village Board of Trustees Meeting held on March 23, 2026.

10. Ordinance for First Reading

11. Ordinance for Second Reading

12. Ordinances

- a. An Ordinance providing for the issue of not to exceed \$9,500,000 General Obligation Refunding Bonds of the Village of Villa Park, DuPage County, Illinois, for the purpose of refunding outstanding obligations of the Village, providing for the levy and collection of a direct annual tax sufficient to pay the principal and interest on said bonds, and authorizing the sale of said bonds to the purchaser thereof.

This ordinance essentially refinances the Village's General Obligation Bonds from 2014 to save interest costs.

13. Resolutions

- a. Resolution of the Village of Villa Park, DuPage County, Illinois Amending Its Travel Expense Reimbursement Regulations

This resolution would adopt minor changes to the Village's Travel Policy regarding approvals and documentation for types of travel.

- b. Resolution authorizing the replacement of the HVAC Control System at the Villa Park Police Department, 40 S. Ardmore Avenue in an amount not to exceed \$43,756.00.

- c. Resolution of the Village of Villa Park, DuPage County, Illinois, for Construction on State Highways

A state highway permit must be obtained before starting any construction work on state rights-of-way. State highway permits also require that a surety bond be obtained for each permit, or, in the case of municipalities, that a blanket resolution be approved guaranteeing that the work and restoration will be performed properly.

- d. Resolution of the Village of Villa Park, DuPage County, Illinois Approving a Temporary Commemorative Village Flag in Honor of the 250th Anniversary of the Signing of the Declaration of Independence

14. Unfinished Business

15. New Business

16. Village Commission Reports

17. Village Clerk's Report

18. Village Trustees' Report

19. Village President's Report

20. Village Manager's Report

21. Executive Session

- a. Pursuant to 5 ILCS 120/2(c)(1), the appointment, employment, compensation, discipline, performance, or dismissal of specific employees of the public body or legal counsel for the public body.

22. Adjournment

The Villa Park Village Hall is subject to the requirements of the Americans with Disabilities Act of 1990. An elevator is operational at the north side entrance to the Village Hall during normal work hours and also during evenings. Individuals with special needs are requested to contact the Village's Compliance Officer at (630) 834-8500 so that reasonable accommodations can be made for those persons.



Village of Villa Park

20 South Ardmore Avenue, Villa Park, Illinois 60181-2696

PROCLAMATION RECOGNIZING APRIL 2026 AS AUTISM AWARENESS MONTH

WHEREAS, Autism Awareness Month is observed throughout April 2026; the theme is “Celebrate Differences” this year; and

WHEREAS, Autism is a pervasive developmental disorder affecting the social, behavioral and communication skills of those affected by it; and

WHEREAS, there is no cure for autism, documentation shows early and intensive treatment in individuals with autism can tremendously change lives; and

WHEREAS, this disorder requires dedicated support from family, health, social and educational workers on a daily basis; and

WHEREAS, Villa Park is promoting Autism Awareness and acceptance in our community by urging others to create a supportive, inclusive and compassionate environment through changing attitudes and celebrating differences.

NOW THEREFORE, I, Kevin Patrick, President of the Village of Villa Park, do hereby proclaim April 2026 to be Autism Awareness Month in the Village of Villa Park, Illinois.

IN WITNESS WHEREOF, I have hereunto set my hand this 13th day of April 2026.

Kevin Patrick, Village President

Rolf Laukant, Village Clerk



MEMORANDUM

TO: Village Board of Trustees
FROM: Rich Salerno
DATE: April 13, 2026
SUBJECT: Proclamation Declaring April 24, 2026, as Arbor Day 2026 in the Village of Villa Park, Illinois.

RECOMMENDED ACTION:

BACKGROUND:

DISCUSSION:



PROCLAMATION

OF APRIL 24, 2026, AS ARBOR DAY IN THE VILLAGE OF VILLA PARK

- WHEREAS,** In 1872, J. Sterling Morton proposed that a special day be set aside for planting trees to be known as Arbor Day; and
- WHEREAS,** Arbor Day is now observed around the world and is celebrated on the last Friday in April in the State of Illinois; and
- WHEREAS,** Trees can be a solution to combating climate change by reducing the erosion of our precious topsoil by wind and water, cutting heating and cooling costs, moderating the temperature, cleaning the air, producing life-giving oxygen, and providing habitat for wildlife; and
- WHEREAS,** Trees are a renewable resource giving us paper, wood for our homes, fuel for our fires, and countless other wood products; and
- WHEREAS,** Trees in our Village increase property values, enhance the economic vitality of business areas, and beautify our community; and
- WHEREAS,** For the 41st year in a row Villa Park has been designated as a Tree City USA; and
- WHEREAS,** For the 5th year in a row Villa Park has been designated as a Tree City USA Growth Award recipient; and
- WHEREAS,** Villa Park will celebrate Arbor Day with a tree planting ceremony on April 24, 2026.
- NOW, THEREFORE,** I, Kevin Patrick, Village President of the Village of Villa Park, do hereby proclaim April 24, 2026, as **ARBOR DAY** in the Village of Villa Park.
- FURTHER,** I urge all citizens to plant trees to gladden the heart and promote the wellbeing of this and future generations.
- DATED THIS** 13th day of April, 2026.

Kevin Patrick, Village President

ATTEST:

Rolf Laukant, Village Clerk



Village of Villa Park

20 South Ardmore Avenue, Villa Park, Illinois 60181-2696

PROCLAMATION RECOGNIZING APRIL 2026 AS DISTRACTED DRIVING AWARENESS MONTH

WHEREAS, April 2026 is officially recognized as Distracted Driving Awareness Month with growing indicators that distracted driving in young adults is approximately 31% nationwide; and

WHEREAS, the National Highway Traffic Safety Administration (NHTSA), at last official count stated 3,275 people were killed and an estimated 324,819 were injured in motor vehicle crashes involving distracted drivers; and

WHEREAS, the Illinois Secretary of State actively promotes initiatives such as "One Road. One Focus" which includes educational videos for teen drivers, displaying of ads and the coordination of high volume patrols to assist in combating distracted driving; and

WHEREAS, Villa Park is asking every resident and business to promote and commit to distraction free driving in April 2026 and beyond to make our roadways safer and to save lives.

NOW THEREFORE, I, Kevin Patrick, President of the Village of Villa Park, do hereby proclaim April 2026 to be Distracted Driving Awareness Month in the Village of Villa Park, Illinois.

IN WITNESS WHEREOF, I have hereunto set my hand this 13th day of April 2026.

Kevin Patrick, Village President

Rolf Laukant, Village Clerk



Village of Villa Park

20 South Ardmore Avenue, Villa Park, Illinois 60181-2696

PROCLAMATION RECOGNIZING APRIL 2026 AS FAIR HOUSING MONTH

WHEREAS, the right to Equal Housing Opportunity is a fundamental principle of a just and inclusive society; and

WHEREAS, the passage of the Fair Housing Act on April 11, 1968, as part of the Civil Rights Act of 1968, established national protections that prohibit discrimination in housing based on race, color, religion, sex, national origin, disability, and familial status; and

WHEREAS, April is recognized nationally as Fair Housing Month, providing communities an opportunity to reaffirm their commitment to fair housing principles and to ensuring that all residents have access to safe, decent, and affordable housing; and

WHEREAS, the Village of Villa Park is committed to promoting fairness, inclusivity, and equal opportunity in housing and supports efforts that help ensure residents are treated with dignity and respect in housing transactions; and

WHEREAS, organizations throughout DuPage County, including DuPage United, bring together faith communities, nonprofit organizations, and civic institutions to build collaborative relationships, develop community leadership, and advocate for solutions that strengthen communities and expand access to housing opportunities; and

WHEREAS, the Village of Villa Park recognizes and appreciates the work of DuPage United and its partner institutions in fostering civic engagement, promoting dialogue, and working collaboratively with local leaders to address important community issues, including fair and accessible housing; and

WHEREAS, strong communities are built when residents, organizations, and local governments work together to ensure fairness, opportunity, and respect for all;

NOW, THEREFORE, I, Kevin Patrick, Village President of the Village of Villa Park, do hereby proclaim the month of April 2026 as Fair Housing Month in the Village of Villa Park and encourage residents, community organizations, and local leaders to continue supporting the principles of Equal Housing Opportunity and to work together to foster a welcoming and inclusive community.

IN WITNESS WHEREOF, I have hereunto set my hand and caused the seal of the Village of Villa Park to be affixed this 13th day of April, 2026.

Kevin Patrick, Village President

Rolf Laukant, Village Clerk



MEMORANDUM

TO: Village Board of Trustees
FROM:
DATE: April 13, 2026
SUBJECT: DuPage United Presentation

RECOMMENDED ACTION:

BACKGROUND:

DISCUSSION:



Village Commission Application

Name

William (Bill) Zucker

Address

██████████ Villa Park, Illinois 60181

Primary Phone

██████████

Work Phone

Email

██████████

Have you resided within the corporate limits of Villa Park for at least one year?

Yes

Are you between the ages of 13-17?

No

I am interested in serving on the following Commission(s), listed in order of preference:

- **Community F.U.N. Commission**
- **Villa Fest Subcommittee**
- **Community Recreation Commission**
- **Garden Village Commission**
- **G.R.E.E.N. Commission**
- **Villa Park Growth Commission**
- **Historical Preservation Commission**
- **Plan Commission**
- **Zoning Board of Appeals**
- **Senior Concerns Commission**
- **Board of Fire and Police**
- **Police Pension Fund Board**
- **Firefighter's Pension Fund Board**
- **Sugar Creek Golf Course Administrative Board**

First Preference:

Board of Fire and Police

Second Preference:

Third Preference:

Employment Background:

Retired. Worked for Sears Robuck majority of my life and I retired about ██████ years ago

Education Background:

HS diploma Austin

Have you previously served as an elected or appointed official in Villa Park?

No

Would you be able to attend the Commission's meetings at the dates and times as listed on the Village's website at invillapark.com?

Yes

Signature

William Zucker

Date of Application

3/25/2026



Village Commission Application

Name

Jennifer Hamilton

Address

[REDACTED]

Primary Phone

[REDACTED]

Work Phone

[REDACTED]

Email

[REDACTED]

Have you resided within the corporate limits of Villa Park for at least one year?

No

Are you between the ages of 13-17?

No

I am interested in serving on the following Commission(s), listed in order of preference:

- **Community F.U.N. Commission**
- **Villa Fest Subcommittee**
- **Community Recreation Commission**
- **Garden Village Commission**
- **G.R.E.E.N. Commission**
- **Villa Park Growth Commission**
- **Historical Preservation Commission**
- **Plan Commission**
- **Zoning Board of Appeals**
- **Senior Concerns Commission**
- **Board of Fire and Police**
- **Police Pension Fund Board**
- **Firefighter's Pension Fund Board**
- **Sugar Creek Golf Course Administrative Board**

First Preference:

G.R.E.E.N. Commission

Second Preference:

Garden Village Commission

Third Preference:

Employment Background:

Undergraduate Research Assistant at Purdue University studying climate technologies.

[REDACTED]

[REDACTED]

Education Background:

Bachelor of Science from Purdue University in Natural Resources and Environmental Science, concentration in Environmental Policy

Have you previously served as an elected or appointed official in Villa Park?

No

Would you be able to attend the Commission's meetings at the dates and times as listed on the Village's website at invillapark.com?

Yes

Signature

A handwritten signature in black ink that reads "Joseph A. Hantke". The signature is written in a cursive style with a large initial 'J' and 'A'.

Date of Application

4/7/2026

**BILL LISTING TO BE PRESENTED TO
THE VILLAGE BOARD OF TRUSTEES
ON 4.13.26 CY WEEKLY CHECK RUN
DATED 3.20.26**

INVOICE DISTRIBUTION REPORT FOR VILLAGE OF VILLA PARK
EXP CHECK RUN DATES 03/23/2026 - 03/23/2026
POSTED AND UNPOSTED
OPEN AND PAID

GL Number	Invoice Line Desc	Vendor Name	Invoice Description	Amount	Check Number
Fund: 10 CORPORATE FUND					
Department: 110 PUBLIC AFFAIRS					
10-110-530300	IML 2026 MEMBERSHIP DUES	ILLINOIS MUNICIPAL LEAGUE	IML 2026 MEMBERSHIP DUES	1,750.00	None
10-110-565600	2026 Q1 RECORDS MANAGEMENT	LAUTERBACH & AMEN LLP	RECORDS MANAGEMENT SERVICES	1,625.00	None
Total Department 110 PUBLIC AFFAIRS				3,375.00	
Department: 121 INFORMATION TECHNOLOGY					
10-121-529901	MONTHLY TIMECLOCK SOFTWARE	COMMEG SYSTEMS INC	MONTHLY TIMECLOCK SOFTWARE	642.00	None
10-121-529901	PD DOOR REPAIRS	GERATY & COMPANY ACCESS CO	PD DOOR REPAIRS	450.00	None
10-121-529901	PD DOOR SOFTWARE MODIFICAT	GERATY & COMPANY ACCESS CO	PD DOOR SOFTWARE MODIFICATIONS	450.00	None
Total Department 121 INFORMATION TECHNOLOGY				1,542.00	
Department: 130 FINANCE					
10-130-529900	LEGAL RE;CY2024 TREASURER	ROCK VALLEY PUBLISHING LLC	LEGAL RE;CY2024 TREASURERS REPORT	846.00	None
Total Department 130 FINANCE				846.00	
Department: 140 COMMUNITY DEVELOPMENT					
10-140-520200	WILLOBROOK LUNCH FUNDRAISE	VILLA PARK CHAMBER OF COMM	WILLOBROOK LUNCH FUNDRAISER TICKET	25.00	None
10-140-522400	PERMIT FEE REIMBURSEMENT	WILLIAM SODD	646 S CORNELL AVE - HOME FLOOD PREVEN	200.00	None
10-140-529900	OTHER CONTRACTUAL SERVICES	ELEVATOR INSPECTION SVC CO	ELEVATOR RE INSPECTIONS	75.00	None
Total Department 140 COMMUNITY DEVELOPMENT				300.00	
Department: 160 BUILDINGS & GROUNDS					
10-160-529900	POLICE FRAGRANCE DISPENSER	STATE INDUSTRIAL PRODUCTS	POLICE FRAGRANCE DISPENSER SYSTEM REF	222.48	None
10-160-529900	PD ALARM MONTITORING 03/01	JOHNSON CONTROLS SECURITY	PD ALARM MONTITORING 03/01/26 - 05/31	116.10	None
10-160-529900	11 W HOME AVE WIRELESS MON	JOHNSON CONTROLS SECURITY	11 W HOME AVE WIRELESS MONITORING	164.36	None
10-160-529900	POLICE FRAGRANCE DISPENSER	STATE INDUSTRIAL PRODUCTS	POLICE FRAGRANCE DISPENSER SYSTEM REF	222.48	None
10-160-529900	VH FRAGRANCE SYSTEM REFILL	STATE INDUSTRIAL PRODUCTS	VH FRAGRANCE SYSTEM REFILL	229.15	None
10-160-529900	FD 82 - FIRE ALARM WIRELES	JOHNSON CONTROLS SECURITY	FD 82 - FIRE ALARM WIRELESS MONITORIN	108.00	None
10-160-529900	ELEVATOR VILLA PARK VLG HA	TK ELEVATOR CORPORATION	ELEVATOR VILLA PARK VLG HALL MAINTENA	1,894.19	None
10-160-531500	SASH LOCK SATIN NICKEL & P	LOMBARD ACE HARDWARE (FIRE	SASH LOCK SATIN NICKEL & PULL UTILITY	35.94	None
10-160-531500	CARPET FOR LACTATION ROOM	TERRACE FLOOR COVERING	CARPET FOR LACTATION ROOM	650.00	None
10-160-531500	IOWA TEMP FIRE STATION PIP	PORTER PIPE AND SUPPLY	IOWA TEMP FIRE STATION PIPE REPAIR	59.68	None
Total Department 160 BUILDINGS & GROUNDS				3,702.38	
Department: 207 POLICE-RECORDS					
10-207-520200	PEER SUPPORT TRAINING- OFC	DU-COMM	PEER SUPPORT TRAINING- OFC FRANCO	475.00	None
10-207-520207	TRAINING & CONFERENCES	NORTHWESTERN UNIVERSITY	POLICE STAFF & COMMAND-SGT HRUBY	4,600.00	None
10-207-521000	POLE CAMERAS & EMPL CELLS	VERIZON WIRELESS	POLE CAMERAS & EMPL CELLS	2,036.64	None
10-207-521000	EMPLOYEE CELLS	VERIZON WIRELESS	EMPLOYEE CELLS	1,256.53	None
10-207-529900-0CS027	UNLIMITED INT/EXT WASH	DELTA SONIC CAR WASH SYSTE	UNLIMITED INT/EXT WASH	413.00	None
10-207-530100	BODY ARMOR & MOLLE - OFC J	JG UNIFORMS INC	BODY ARMOR & MOLLE - OFC J. KUBISH	1,280.00	None
10-207-532009	EAR EXAM - K9 LUKE	PARTNERS AND PAWS VETERINA	EAR EXAM - K9 LUKE	506.86	None
Total Department 207 POLICE-RECORDS				10,568.03	
Department: 211 FIRE					
10-211-520201	INSPECTOR II COURSE - SG	ILLINOIS FIRE INSPECTORS A	INSPECTOR II COURSE - SG	350.00	None
10-211-520201	COMMON PASSENGER VEHICLE R	NIPSTA. IL	COMMON PASSENGER VEHICLE RESCUE - SS	1,435.00	None
10-211-529901	POWER LIFT COT ANNUAL MAIN	STRYKER SALES CORPORATION	POWER LIFT COT ANNUAL MAINT. 40075281	2,278.30	None
10-211-529901	RETAINER KIT, PRESSURE GAU	AIR ONE EQUIPMENT INC	RETAINER KIT, PRESSURE GAUGE	85.00	None
10-211-529901	STAIR CHAIR BATTERY CHARGE	STRYKER SALES CORPORATION	STAIR CHAIR BATTERY CHARGER MOUNT PLA	52.80	None
10-211-529901	AMBULANCE BILLING FEES - F	PARAMEDIC BILLING SERVICES	AMBULANCE BILLING FEES - FEB 2026	1,015.40	None
10-211-539901	CREDIT MEMO 3.2.2026	STRYKER SALES CORPORATION	STAIR CHAIR ALVARIUM BATTERY KITS	(68.22)	None

INVOICE DISTRIBUTION REPORT FOR VILLAGE OF VILLA PARK

EXP CHECK RUN DATES 03/23/2026 - 03/23/2026

POSTED AND UNPOSTED
OPEN AND PAID

GL Number	Invoice Line Desc	Vendor Name	Invoice Description	Amount	Check Number
Fund: 10 CORPORATE FUND					
Department: 211 FIRE					
10-211-539901	CREDIT MEMO INVOICE #92115	STRYKER SALES CORPORATION	POWER LIFT COT ANNUAL MAINT. 40075281	(1,961.26)	None
10-211-539901	COPIER BLACK TONER CARTRID	WAREHOUSE DIRECT	COPIER BLACK TONER CARTRIDGE REPLACEM	189.12	None
10-211-539901	COPIER BLACK TONER CARTRID	WAREHOUSE DIRECT	COPIER BLACK TONER CARTRIDGE REPLACEM	189.12	None
10-211-539901	VEHICLE CHARGERS	EMERGENCY TELEPHONE SYSTEM	VEHICLE CHARGERS	794.00	None
Total Department 211 FIRE				4,359.26	
Total Fund 10 CORPORATE FUND				24,692.67	
Fund: 11 CAPITAL / BUILDING & LAND IMPROVE FUND					
Department: 206 BUILDING IMPROVEMENTS					
11-206-540102-FD0001	ST. 81/ICC PROJ - DEMO CAB SK ELECTRONICS		ST. 81/ICC PROJ - DEMO CABLE RELOCATI	630.00	None
Total Department 206 BUILDING IMPROVEMENTS				630.00	
Total Fund 11 CAPITAL / BUILDING & LAND IMPROVE FUND				630.00	
Fund: 19 DUI TECHNOLOGY FUND					
Department: 520 CONTRACTUAL					
19-520-540101	DURANGO CU/ANTENNA COMBO M	STALKER RADAR APPLIED CONC	DURANGO CU/ANTENNA COMBO MOUNT	210.00	None
Total Department 520 CONTRACTUAL				210.00	
Total Fund 19 DUI TECHNOLOGY FUND				210.00	
Fund: 35 RECREATION FUND					
Department: 201 ADMINISTRATION					
35-201-531701	OFFICE SUPPLIES - WHITE CA	GARVEY'S OFFICE PRODUCTS	OFFICE SUPPLIES - WHITE CARD STOCK	22.47	None
35-201-531701	OFFICE SUPPLIES - GREEN CO	GARVEY'S OFFICE PRODUCTS	OFFICE SUPPLIES - GREEN COPY PAPER	10.39	None
Total Department 201 ADMINISTRATION				32.86	
Department: 216 PRP-BLDG & GROUNDS					
35-216-529916	VPRC ALARM SYSTEM MONITORI	SMG SECURITY SYSTEMS INC	VPRC ALARM SYSTEM MONITORING 03/01/20	690.00	None
35-216-531416	JANITORAL SUPPLIES FOR FLO	WAREHOUSE DIRECT	JANITORAL SUPPLIES FOR FLOOR MACHINE	57.78	None
Total Department 216 PRP-BLDG & GROUNDS				747.78	
Department: 235 PROGRAMS					
35-235-529935	CONTRACTUAL DOG OBEDIENCE	DOGS CAN DO LLC	CONTRACTUAL DOG OBEDIENCE CLASSES 2/2	957.60	None
35-235-529935	CONTRACTUAL CHEESE CLASS 3	FULL CIRCLE CHEESE	CONTRACTUAL CHEESE CLASS 3.10.26	108.00	None
35-235-529935	CY26 WINTER BASKETBALL CON	DUPAGE HIGH SCHOOL DISTRIC	CY26 WINTER BASKETBALL CONTRACTUAL SE	427.50	None
35-235-529935	CY26 WINTER BASKETBALL CON	DUPAGE HIGH SCHOOL DISTRIC	CY26 WINTER BASKETBALL CONTRACTUAL SE	371.25	None
35-235-529935	OTHER CONTRACTUAL SERVICES	ADDISON ICE LLC	CY26 CONTRACTUAL ICE SKATING LESSONS	660.00	None
35-235-529935	OTHER CONTRACTUAL SERVICES	COOK, NATHAN	CY26 CONTRACTUAL BASKETBALL LEAGUE SE	492.00	None
Total Department 235 PROGRAMS				3,016.35	
Total Fund 35 RECREATION FUND				3,796.99	
Fund: 65 EQUIPMENT REPLACEMENT FUND					
Department: 202 EQUIPMENT AND SUPPLIES					
65-202-540100	2026 WESTERN STAR PLOW TRU	LINDCO EQUIPMENT SALES INC	2026 WESTERN STAR PLOW TRUCK CHASSIS	130,944.00	None
65-202-540100	STAIR CHAIR ALVARIUM BATTE	STRYKER SALES CORPORATION	STAIR CHAIR ALVARIUM BATTERY KITS	1,955.20	None
Total Department 202 EQUIPMENT AND SUPPLIES				132,899.20	
Total Fund 65 EQUIPMENT REPLACEMENT FUND				132,899.20	
Fund: 83 WASTEWATER FUND					

INVOICE DISTRIBUTION REPORT FOR VILLAGE OF VILLA PARK

EXP CHECK RUN DATES 03/23/2026 - 03/23/2026

POSTED AND UNPOSTED
OPEN AND PAID

GL Number	Invoice Line Desc	Vendor Name	Invoice Description	Amount	Check Number
Fund: 83 WASTEWATER FUND					
Department: 202 EQUIPMENT AND SUPPLIES					
83-202-540102	646 S CORNELL AVE - HOME F WILLIAM SODD		646 S CORNELL AVE - HOME FLOOD PREVEN	3,050.00	None
Total Department 202 EQUIPMENT AND SUPPLIES				3,050.00	
Total Fund 83 WASTEWATER FUND				3,050.00	

INVOICE DISTRIBUTION REPORT FOR VILLAGE OF VILLA PARK

EXP CHECK RUN DATES 03/23/2026 - 03/23/2026

POSTED AND UNPOSTED
OPEN AND PAID

GL Number	Invoice Line Desc	Vendor Name	Invoice Description	Amount	Check Number
--- TOTALS BY FUND ---					
		10	CORPORATE FUND	24,692.67	
		11	CAPITAL / BUILDING & LAND IMPROVE FUN	630.00	
		19	DUI TECHNOLOGY FUND	210.00	
		35	RECREATION FUND	3,796.99	
		65	EQUIPMENT REPLACEMENT FUND	132,899.20	
		83	WASTEWATER FUND	3,050.00	
		Total For All Funds:		<u>165,278.86</u>	

Unto My

Sharon 3-20-26

**BILL LISTING TO BE PRESENTED TO
THE VILLAGE BOARD OF TRUSTEES
ON 4.13.26 CY WEEKLY CHECK RUN
DATED 3.30.26**

INVOICE DISTRIBUTION REPORT FOR VILLAGE OF VILLA PARK

EXP CHECK RUN DATES 03/30/2026 - 03/30/2026
POSTED AND UNPOSTED
OPEN AND PAID

GL Number	Invoice Line Desc	Vendor Name	Invoice Description	Amount	Check Number
Fund: 10 CORPORATE FUND					
Department: 110 PUBLIC AFFAIRS					
10-110-521000	WIRELESS SERVICE FROM 01/2 VERIZON WIRELESS PW		WIRELESS SERVICE FROM 01/27/26 to 02/	38.07	None
10-110-521102	ADMINISTRATIVE HEARINGS FE OTTOSEN DINOLFO		ADMINISTRATIVE HEARINGS FEBRUARY 2026	1,347.50	None
10-110-565600	BFPC SECRETARIAL SERVICE J MAGNUSSEN, VALERIE		BFPC SECRETARIAL SERVICE JAN/FEB/MAR	200.00	None
10-110-565600	BFPC SECRETARIAL SERVICE F MAGNUSSEN, VALERIE		BFPC SECRETARIAL SERVICE JAN/FEB/MAR	200.00	None
10-110-565600	BFPC SECRETARIAL SERVICE M MAGNUSSEN, VALERIE		BFPC SECRETARIAL SERVICE JAN/FEB/MAR	200.00	None
10-110-566700	REIMBURSEMENT FOR FINDING DIEDERICH, ELIZA		REIMBURSEMENT FOR FINDING LUCKY EVENT	100.00	None
Total Department 110 PUBLIC AFFAIRS				2,085.57	
Department: 120 MANAGER-ADMINISTRATION					
10-120-521000	WIRELESS SERVICE FROM 01/2 VERIZON WIRELESS PW		WIRELESS SERVICE FROM 01/27/26 to 02/	114.21	None
10-120-521000	WIRELESS SERVICE FROM 01/2 VERIZON WIRELESS PW		WIRELESS SERVICE FROM 01/27/26 to 02/	24.02	None
Total Department 120 MANAGER-ADMINISTRATION				138.23	
Department: 121 INFORMATION TECHNOLOGY					
10-121-527001	MICROSOFT WINDOWS SERVER L HEARTLAND BUSINESS SYSTEMS		MICROSOFT WINDOWS SERVER LICENSING	15,002.64	None
10-121-529901	VIDEO DOORBELL FD81 LABOR NOBLETEC LLC		VIDEO DOORBELL FD81	270.00	None
10-121-529901	IMAGE DEPLOYER SOFTWARE RE ZOHU CORPORATION		IMAGE DEPLOYER SOFTWARE RENEWAL	645.00	None
Total Department 121 INFORMATION TECHNOLOGY				15,917.64	
Department: 130 FINANCE					
10-130-531700	PERSONNEL CHANGE NOTICES PRINTSMART PRINTING &		PERSONNEL CHANGE NOTICES	378.00	None
Total Department 130 FINANCE				378.00	
Department: 140 COMMUNITY DEVELOPMENT					
10-140-521000	WIRELESS SERVICE FROM 01/2 VERIZON WIRELESS PW		WIRELESS SERVICE FROM 01/27/26 to 02/	228.42	None
10-140-521000	WIRELESS SERVICE FROM 01/2 VERIZON WIRELESS PW		WIRELESS SERVICE FROM 01/27/26 to 02/	120.10	None
Total Department 140 COMMUNITY DEVELOPMENT				348.52	
Department: 150 CENTRAL SERVICES					
10-150-525000	HEALTH INSURANCE; APR 2026 BLUE CROSS BLUE SHIELD		HEALTH INSURANCE; APR 2026	379,572.23	None
10-150-525000	FEB FSA MONTHLY FEE WEX HEALTH INC.		FEB FSA MONTHLY FEE	433.74	None
10-150-525000	LIFE INSURANCE; MAR DEARBORN NATIONAL LIFE INS		LIFE INSURANCE; MAR	8,191.76	None
10-150-525000	LIFE INSURANCE; APR DEARBORN NATIONAL LIFE INS		LIFE INSURANCE; APR	8,251.10	None
10-150-525000	RETIREE SUPPLEMENTAL PLAN; BESTCO BENEFIT PLANS LLC		RETIREE SUPPLEMENTAL PLAN; APR	1,821.20	None
10-150-525000	BREE HEALTH FEB-JUL 2026 EMPLOYEE NETWORK INC		BREE HEALTH FEB-JUL 2026	1,494.00	None
10-150-526000	FEB 2026 REV. BASE LATE FE IRMA		FEB 2026 REV. BASE LATE FEE	2,800.00	None
10-150-526100	FEB 2026 CLAIM DEDUCTIBLES IRMA		FEB 2026 CLAIM DEDUCTIBLES	609.10	None
10-150-526100	FEB 2026 CLAIM DEDUCTIBLES IRMA		FEB 2026 CLAIM DEDUCTIBLES	1,092.10	None
10-150-526100	FEB 2026 CLAIM DEDUCTIBLES IRMA		FEB 2026 CLAIM DEDUCTIBLES	3,673.20	None
10-150-526100	FEB 2026 CLAIM DEDUCTIBLES IRMA		FEB 2026 CLAIM DEDUCTIBLES	106.96	None
10-150-526100	FIRE HYDRANT, VALVE BOX, H MID-AMERICAN WATER, INC.		FIRE HYDRANT, VALVE BOX, HARDWARE	5,998.72	None
10-150-527000	COPIER USAGE 3.5-4.4.26 GORDON FLESCH CO. INC		COPIER USAGE 3.5-4.4.26	3,084.09	None
10-150-531700	VH OFFICE FURNITURE VILLA PARK OFFICE EQUIPMEN		VH OFFICE FURNITURE	1,803.96	None
10-150-531700	ENVELOPES PRINTSMART PRINTING &		ENVELOPES	836.00	None
Total Department 150 CENTRAL SERVICES				419,768.16	
Department: 160 BUILDINGS & GROUNDS					
10-160-521900	21 W PLYMOUTH 2.10.26-3.11 COMMONWEALTH EDISON CO		21 W PLYMOUTH 2.10.26-3.11.26	227.23	None
10-160-521900	SIREN 2.9.26-3.10.26 COMMONWEALTH EDISON CO		SIREN 2.9.26-3.10.26	48.87	None
10-160-521900	JACKSON POND 1.23.26-2.23. COMMONWEALTH EDISON CO		JACKSON POND 1.23.26-2.23.26	85.06	None
10-160-521900	106 S VILLA 11.5-12.27.25 COMMONWEALTH EDISON CO		106 S VILLA 11.5-12.27.25	0.00	None

INVOICE DISTRIBUTION REPORT FOR VILLAGE OF VILLA PARK

EXP CHECK RUN DATES 03/30/2026 - 03/30/2026

POSTED AND UNPOSTED

OPEN AND PAID

GL Number	Invoice Line Desc	Vendor Name	Invoice Description	Amount	Check Number
Fund: 10 CORPORATE FUND					
Department: 160 BUILDINGS & GROUNDS					
10-160-522000	220 S VILLA 1.5-3.5.26	NICOR GAS	220 S VILLA 1.5-3.5.26	484.96	None
10-160-522000	40 S ARDMORE 2.4.26-3.5.26	NICOR GAS	40 S ARDMORE 2.4.26-3.5.26	620.15	None
10-160-522000	24-26 W HOME 2.4.26-3.5.26	NICOR GAS	24-26 W HOME 2.4.26-3.5.26	0.00	None
10-160-522000	1440 S ARDMORE 2.9.26-3.10	NICOR GAS	1440 S ARDMORE 2.9.26-3.10.26	0.00	None
10-160-522000	51 S ARDMORE 2.4.26-3.5.26	NICOR GAS	51 S ARDMORE 2.4.26-3.5.26	0.00	None
10-160-522000	11 W HOME 12.5-2.4.26	NICOR GAS	11 W HOME 12.5-2.4.26	0.00	None
10-160-522000	100 W HOME 2.4.26-3.5.26	NICOR GAS	100 W HOME 2.4.26-3.5.26	0.00	None
10-160-522000	102 W PLYMOUTH 2.4.26-3.5.	NICOR GAS	102 W PLYMOUTH 2.4.26-3.5.26	0.00	None
10-160-529900	QTR DEPOT BURGLAR ALARM	SMG SECURITY SYSTEMS INC	QTR BURGLAR ALARM	1,986.36	None
10-160-529900	STATION 81 ANNUAL SPRINKLE P A	CRIMSON FIRE RISK SERV	STATION 82 (5 YEAR SPRINKLER INSPECTI	3,307.00	None
Total Department 160 BUILDINGS & GROUNDS				6,759.63	
Department: 170 COMMUTER PARKING LOT					
10-170-521900	METRA STN PARK LOT 2.10.26	COMMONWEALTH EDISON CO	METRA STN PARK LOT 2.10.26-3.11.26	42.91	None
10-170-522000	ES BEVERLY 1ST TERRACE 2.4	NICOR GAS	ES BEVERLY 1ST TERRACE 2.4.26-3.5.26	0.00	None
10-170-529900	QTR METRA BURGLAR MONITORI	SMG SECURITY SYSTEMS INC	QTR BURGLAR ALARM	114.03	None
Total Department 170 COMMUTER PARKING LOT				156.94	
Department: 180 GARAGE					
10-180-521000	WIRELESS SERVICE FROM 01/2	VERIZON WIRELESS PW	WIRELESS SERVICE FROM 01/27/26 to 02/	38.07	None
10-180-531000	FIE E80 FIREWALL AIR LINE	MACQUEEN EMERGENCY	FIE E80 FIREWALL AIR LINE PASS THROUG	42.92	None
10-180-531000	PARKS 252 MODULE FOR REAR	BRAD MANNING FORD INC	PARKS 252 MODULE FOR REAR END	121.67	None
10-180-531000	FIRE M82 CLEAR MARKER LIGH	FOSTER COACH SALES INC	FIRE M82 CLEAR MARKER LIGHTS	97.88	None
10-180-531000	FIRE M81 TRANSMISSION FILT	ELMHURST FORD	FIRE M81 TRANSMISSION FILTER	84.50	None
10-180-531500	PW 62 SAFETY LANE TEST	SUBURBAN DRIVELINE INC	PW 62 SAFETY LANE TEST	45.00	None
10-180-531500	PW 94 SAFETY LANE TEST	SUBURBAN DRIVELINE INC	PW 94 SAFETY LANE TEST	45.00	None
10-180-531500	PW 65 SAFETY LANE TEST	SUBURBAN DRIVELINE INC	PW 65 SAFETY LANE TEST	45.00	None
10-180-531500	PW 19 SAFETY LANE TEST	SUBURBAN DRIVELINE INC	PW 19 SAFETY LANE TEST	45.00	None
10-180-531500	PW 48 SAFETY LANE TEST	SUBURBAN DRIVELINE INC	PW 48 SAFETY LANE TEST	45.00	None
10-180-531500	PW 16 SAFETY LANE TEST	SUBURBAN DRIVELINE INC	PW 16 SAFETY LANE TEST	45.00	None
10-180-531500	PARKS 250 SAFETY LANE TEST	SUBURBAN DRIVELINE INC	PARKS 250 SAFETY LANE TEST	45.00	None
10-180-531500	PW 1 SAFETY LANE TEST	SUBURBAN DRIVELINE INC	PW 1 SAFETY LANE TEST	67.00	None
10-180-531500	PW 90 SAFETY LANE TEST	SUBURBAN DRIVELINE INC	PW 90 SAFETY LANE TEST	67.00	None
Total Department 180 GARAGE				834.04	
Department: 207 POLICE-RECORDS					
10-207-520200	MEAL REIMBURSEMENT - TRAIN	HRUBY, BRYAN	MEAL REIMBURSEMENT - TRAINING - HRUBY	13.67	None
10-207-520200	MEAL REIMBURSEMENT - TRAIN	MARTINEZ, CASSANDRA	MEAL REIMBURSEMENT - TRAINING - MARTI	188.48	None
10-207-529109	STRAY HOLDING & VACCINATTO	DUPAGE COUNTY ANIMAL SERVI	STRAY HOLDING & VACCINATION	150.00	None
10-207-529900-ocs003	7-POLYGRAPH SERVICES	SHAUGHNESSY, KEVIN W	7-POLYGRAPH SERVICES	1,925.00	None
10-207-529900-ocs019	PHLEBOTOMY SRV-VPPC2600414	ILLINOIS PHLEBOTOMY SERVIC	PHLEBOTOMY SRV-VPPC2600414	425.00	None
10-207-529900-ocs038	COMM POLICE CONNECT/PRO-ST	TARGETSOLUTIONS LEARNING L	COMM POLICE CONNECT/PRO-STANDARDS	1,823.26	None
10-207-529900-ocs044	SOCIAL WORKER-LOCAL SRVS F	NORTHEAST DUPAGE FAMILY &	SOCIAL WORKER-LOCAL SRVS FEB 2026	7,101.27	None
10-207-530100	BODY ARMOR-SGT WALSH	JG UNIFORMS INC	BODY ARMOR-SGT WALSH	995.00	None
Total Department 207 POLICE-RECORDS				12,621.68	
Department: 211 FIRE					
10-211-521001	WIRELESS SERVICE FROM 01/2	VERIZON WIRELESS PW	WIRELESS SERVICE FROM 01/27/26 to 02/	114.21	None
10-211-521001	WIRELESS SERVICE FROM 01/2	VERIZON WIRELESS PW	WIRELESS SERVICE FROM 01/27/26 to 02/	50.08	None
10-211-521001	WIRELESS SERVICE FROM 01/2	VERIZON WIRELESS PW	WIRELESS SERVICE FROM 01/27/26 to 02/	152.28	None
10-211-529901	SENSIT GAS MONITOR REPAIR	SENSIT TECHNOLOGIES	SENSIT GAS MONITOR REPAIR	160.50	None

INVOICE DISTRIBUTION REPORT FOR VILLAGE OF VILLA PARK

EXP CHECK RUN DATES 03/30/2026 - 03/30/2026

POSTED AND UNPOSTED

OPEN AND PAID

GL Number	Invoice Line Desc	Vendor Name	Invoice Description	Amount	Check Number
Fund: 10 CORPORATE FUND					
Department: 211 FIRE					
10-211-529901	SCBA COMPRESSOR REPAIR	AIR ONE EQUIPMENT INC	SCBA COMPRESSOR REPAIR	171.50	None
10-211-529906	GEMT 2025Q3 (7.25-9.25)	IL DEPT OF HEALTHCARE	GEMT 2025Q4 (10.25-12.25)	185,385.26	None
10-211-531701	COPY MACHINE STAPLES	GORDON FLESCH CO. INC	COPY MACHINE STAPLES	102.00	None
10-211-539901	GLOVES FOR AMBULANCES	MMSGGS	GLOVES FOR AMBULANCES	587.50	None
10-211-539901	GLOVES FOR AMBULANCES	MMSGGS	GLOVES FOR AMBULANCES	589.10	None
10-211-539901	TRAUMA BAG	BOUND TREE MEDICAL LLC	TRAUMA BAG	433.25	None
10-211-539901	HOTSTICK VOLTAGE DETECTORS	AIR ONE EQUIPMENT INC	HOTSTICK VOLTAGE DETECTORS	1,202.00	None
Total Department 211 FIRE				188,947.68	
Department: 251 PUBLIC WORKS					
10-251-521001	WIRELESS SERVICE FROM 01/2	VERIZON WIRELESS PW	WIRELESS SERVICE FROM 01/27/26 to 02/	25.04	None
10-251-521001	WIRELESS SERVICE FROM 01/2	VERIZON WIRELESS PW	WIRELESS SERVICE FROM 01/27/26 to 02/	17.64	None
10-251-527001	COPIER USAGE 3.5-4.4.26	GORDON FLESCH CO. INC	COPIER USAGE 3.5-4.4.26	211.24	None
Total Department 251 PUBLIC WORKS				253.92	
Department: 255 PW-TRAFFIC					
10-255-521925	889 W NO STREETLIGHTS 2.10	COMMONWEALTH EDISON CO	889 W NO STREETLIGHTS 2.10.26-3.11.26	57.21	None
10-255-521925	STREETLIGHTS 2 2.9.26-3.11	COMMONWEALTH EDISON CO	STREETLIGHTS 2 2.9.26-3.11.26	40.82	None
10-255-521925	STREETLIGHTS 2.4.26-3.5.26	COMMONWEALTH EDISON CO	STREETLIGHTS 2.4.26-3.5.26	78.32	None
Total Department 255 PW-TRAFFIC				176.35	
Total Fund 10 CORPORATE FUND				648,386.36	
Fund: 11 CAPITAL / BUILDING & LAND IMPROVE FUND					
Department: 202 EQUIPMENT AND SUPPLIES					
11-202-529902	320 E KENILWORTH 2.9.26-3.	NICOR GAS	320 E KENILWORTH 2.9.26-3.11.26	0.00	None
Total Department 202 EQUIPMENT AND SUPPLIES				0.00	
Department: 206 BUILDING IMPROVEMENTS					
11-206-540102-FD0001	FIRE STATION 81 RENOVATION	LITE CONSTRUCTION INC	FIRE STATION 81 RENOVATIONS & TEMPORA	306,829.79	None
11-206-540102-FD0001	VIDEO DOORBELL FD81	NOBLETEC LLC	VIDEO DOORBELL FD81	949.00	None
11-206-540102-PD0001	POLICE DEPT MINI SPLIT INS	ROBE INC	POLICE DEPT MINI SPLIT INSTALLATION	23,254.76	None
Total Department 206 BUILDING IMPROVEMENTS				331,033.55	
Total Fund 11 CAPITAL / BUILDING & LAND IMPROVE FUND				331,033.55	
Fund: 26 TIF 6 FUND-NO ARDMORE/VERMONT					
Department: 241 TIF CAPITAL & CONTRACTUAL					
26-241-529901	OTHER CONTRACT SERV-PEST S	COMMERCIAL PEST MANAGEMENT	PEST CONTROL MATTERS	1,350.00	None
Total Department 241 TIF CAPITAL & CONTRACTUAL				1,350.00	
Total Fund 26 TIF 6 FUND-NO ARDMORE/VERMONT				1,350.00	
Fund: 32 MFT FUND					
Department: 202 EQUIPMENT AND SUPPLIES					
32-202-521925	UTILITY - ELECTRIC	COMMONWEALTH EDISON CO	TRAFFIC SIGNALS 1.13.26-3.12.26	2,774.48	None
32-202-534127	BULK SAFE-T-SALT	MORTON SALT INC	BULK SAFE-T-SALT	9,973.50	None
Total Department 202 EQUIPMENT AND SUPPLIES				12,747.98	
Total Fund 32 MFT FUND				12,747.98	

Fund: 35 RECREATION FUND
Department: 201 ADMINISTRATION

INVOICE DISTRIBUTION REPORT FOR VILLAGE OF VILLA PARK

EXP CHECK RUN DATES 03/30/2026 - 03/30/2026

POSTED AND UNPOSTED

OPEN AND PAID

GL Number	Invoice Line Desc	Vendor Name	Invoice Description	Amount	Check Number
Fund: 35 RECREATION FUND					
Department: 201 ADMINISTRATION					
35-201-521001	WIRELESS SERVICE FROM 01/2	VERIZON WIRELESS PW	WIRELESS SERVICE FROM 01/27/26 to 02/	228.42	None
35-201-522001	338 N IOWA 2.4.26-3.5.26	NICOR GAS	338 N IOWA 2.4.26-3.5.26	0.00	None
35-201-527001	COPIER USAGE 3.5-4.4.26	GORDON FLESCH CO. INC	COPIER USAGE 3.5-4.4.26	337.98	None
35-201-527001	COPIER USAGE 3.5-4.4.26	GORDON FLESCH CO. INC	COPIER USAGE 3.5-4.4.26	307.16	None
Total Department 201 ADMINISTRATION				873.56	
Department: 216 PRP-BLDG & GROUNDS					
35-216-521916	TENNIS CRTS 2.6.26-3.11.26	COMMONWEALTH EDISON CO	TENNIS CRTS 2.6.26-3.11.26	53.07	None
35-216-522216	HEATER REPAIRS AT VPRC	TOTAL AUTOMATION CONCEPTS	HEATER REPAIRS AT VPRC	267.00	None
35-216-522216	HEATER PROGRAM AJUSTMENTS	TOTAL AUTOMATION CONCEPTS	HEATER PROGRAM AJUSTMENTS AT VPRC	356.00	None
35-216-529916	VPRC ALARM SYSTEM MONITORI	SMG SECURITY SYSTEMS INC	VPRC ALARM SYSTEM MONITORING 04/01/26	105.00	None
35-216-529916	QTR IOWA/DEP FIRE AND BURG	SMG SECURITY SYSTEMS INC	QTR BURGLAR ALARM	607.02	None
Total Department 216 PRP-BLDG & GROUNDS				1,388.09	
Total Fund 35 RECREATION FUND				2,261.65	
Fund: 36 PARKS FUND					
Department: 201 ADMINISTRATION					
36-201-521001	WIRELESS SERVICE FROM 01/2	VERIZON WIRELESS PW	WIRELESS SERVICE FROM 01/27/26 to 02/	228.42	None
36-201-521901	TWIN LAKES 1.29.26-2.27.26	COMMONWEALTH EDISON CO	TWIN LAKES 1.29.26-2.27.26	498.49	None
36-201-521901	ROTARY PARK 2.9.26-3.10.26	COMMONWEALTH EDISON CO	ROTARY PARK 2.9.26-3.10.26	49.52	None
36-201-522001	300 N WESTMORE 2.5.26-3.6.	NICOR GAS	300 N WESTMORE 2.5.26-3.6.26	0.00	None
36-201-527001	COPIER USAGE 3.5-4.4.26	GORDON FLESCH CO. INC	COPIER USAGE 3.5-4.4.26	168.99	None
Total Department 201 ADMINISTRATION				945.42	
Department: 202 EQUIPMENT AND SUPPLIES					
36-202-521002	WIRELESS SERVICE FROM 01/2	VERIZON WIRELESS PW	WIRELESS SERVICE FROM 01/27/26 to 02/	75.12	None
36-202-521002	WIRELESS SERVICE FROM 01/2	VERIZON WIRELESS PW	WIRELESS SERVICE FROM 01/27/26 to 02/	5.04	None
Total Department 202 EQUIPMENT AND SUPPLIES				80.16	
Total Fund 36 PARKS FUND				1,025.58	
Fund: 41 SWIMMING POOL & REC FUND					
Department: 301 POOL&REC-ADMIN					
41-301-521901	JEFF POOL 2.10.26-3.11.26	COMMONWEALTH EDISON CO	JEFF POOL 2.10.26-3.11.26	498.08	None
41-301-522001	341 N HARVARD 2.4.26-3.5	NICOR GAS	341 N HARVARD 2.4.26-3.5.26	65.69	None
41-301-522001	320 E WILDWOOD 2.9.26-3.10	NICOR GAS	320 E WILDWOOD 2.9.26-3.10.26	0.00	None
Total Department 301 POOL&REC-ADMIN				563.77	
Total Fund 41 SWIMMING POOL & REC FUND				563.77	
Fund: 60 STREET IMPROVEMENT FUND					
Department: 202 EQUIPMENT AND SUPPLIES					
60-202-521002	WIRELESS SERVICE FROM 01/2	VERIZON WIRELESS PW	WIRELESS SERVICE FROM 01/27/26 to 02/	24.02	None
60-202-521002	WIRELESS SERVICE FROM 01/2	VERIZON WIRELESS PW	WIRELESS SERVICE FROM 01/27/26 to 02/	38.07	None
60-202-521002	DEVICE REIMBURSEMENT - 202	MANTELS, KEVIN	PHONE REIMBURSEMENT - 2025-12 TO 2026	24.99	None
60-202-521002	USAGE REIMBURSEMENT - 2025	MANTELS, KEVIN	PHONE REIMBURSEMENT - 2025-12 TO 2026	24.99	None
60-202-521002	DEVICE REIMBURSEMENT - 202	MANTELS, KEVIN	PHONE REIMBURSEMENT - 2025-12 TO 2026	24.99	None
60-202-521002	USAGE REIMBURSEMENT - 2026	MANTELS, KEVIN	PHONE REIMBURSEMENT - 2025-12 TO 2026	24.99	None
60-202-529902	TRI-TRAIL CONSTRUCTION VIL	ILLINOIS STATE TREASURER I	TRI-TRAIL CONSTRUCTION VILLAGE SHARE	2,430.72	None
Total Department 202 EQUIPMENT AND SUPPLIES				2,592.77	

INVOICE DISTRIBUTION REPORT FOR VILLAGE OF VILLA PARK

EXP CHECK RUN DATES 03/30/2026 - 03/30/2026

POSTED AND UNPOSTED

OPEN AND PAID

GL Number	Invoice Line Desc	Vendor Name	Invoice Description	Amount	Check Number
Fund: 60 STREET IMPROVEMENT FUND					
Department: 210 CONTRACTUAL - SP REV FUNDS					
60-210-529210	ARDMORE (IL 38 TO IL 64) P	CIVILTECH ENGINEERING INC	ARDMORE (IL 38 TO IL 64) PHASE 1 PE	18,024.07	None
60-210-529210	VILLA (WLDWD TO IL 64) PH	CIVILTECH ENGINEERING INC	VILLA (WILDWOOD TO IL 64) PHASE 1 PE	671.96	None
60-210-529210	VILLA (WILDWOOD TO IL 64)	CIVILTECH ENGINEERING INC	VILLA (WILDWOOD TO IL 64) PHASE 2 DE	6,392.25	None
60-210-529210-E00004	PARK (ARDMORE TO CORNELL)	CIVILTECH ENGINEERING INC	PARK (ARDMORE TO CORNELL) PHASE 2 DE	4,422.60	None
60-210-529210-E00009	VILLA (WILDWOOD TO IL 64)	CIVILTECH ENGINEERING INC	VILLA (WILDWOOD TO IL 64) STP GRANT A	394.80	None
Total Department 210 CONTRACTUAL - SP REV FUNDS				29,905.68	
Department: 603 REFERENDUM 2014					
60-603-529203	WESTMORE & WISCONSIN PHASE	CIVILTECH ENGINEERING INC	WESTMORE & WISCONSIN PHASE 2 DE	1,556.40	None
Total Department 603 REFERENDUM 2014				1,556.40	
Total Fund 60 STREET IMPROVEMENT FUND				34,054.85	
Fund: 65 EQUIPMENT REPLACEMENT FUND					
Department: 202 EQUIPMENT AND SUPPLIES					
65-202-539900	ORGANIZER/HALLIGAN/MOUNTS-	CARGORAXX	ORGANIZER/HALLIGAN/MOUNTS-DURANGO	924.95	None
Total Department 202 EQUIPMENT AND SUPPLIES				924.95	
Total Fund 65 EQUIPMENT REPLACEMENT FUND				924.95	
Fund: 82 WATER SUPPLY FUND					
Department: 201 ADMINISTRATION					
82-201-521001	JAN. 26 THRU APRIL 26 CELL	YOUNG, JASON	JAN. 26 THRU APRIL 26 CELL PHONE USAG	199.92	None
82-201-521001	MARCH 2026 CELL PHONE USAG	VENCHUS, THOMAS	MARCH 2026 CELL PHONE USAGE	49.98	None
82-201-521001	WIRELESS SERVICE FROM 01/2	VERIZON WIRELESS PW	WIRELESS SERVICE FROM 01/27/26 to 02/	2.40	None
82-201-521001	WIRELESS SERVICE FROM 01/2	VERIZON WIRELESS PW	WIRELESS SERVICE FROM 01/27/26 to 02/	76.14	None
82-201-521001	WIRELESS SERVICE FROM 01/2	VERIZON WIRELESS PW	WIRELESS SERVICE FROM 01/27/26 to 02/	96.08	None
82-201-521001	MARCH 2026 CELL PHONE USAG	JESSEN, DENNIS	MARCH 2026 CELL PHONE USAGE	49.98	None
82-201-527001	COPIER USAGE 3.5-4.4.26	GORDON FLESCH CO. INC	COPIER USAGE 3.5-4.4.26	211.24	None
Total Department 201 ADMINISTRATION				685.74	
Department: 202 EQUIPMENT AND SUPPLIES					
82-202-521902	520 N PRINCETON 2.11.26-3.	COMMONWEALTH EDISON CO	520 N PRINCETON 2.11.26-3.12.26	216.94	None
82-202-521902	CENTRAL PUMPING STN 2.11.2	COMMONWEALTH EDISON CO	CENTRAL PUMPING STN 2.11.26-3.12.26	371.06	None
82-202-521902	WTR/SWR 2.9.26-3.10.26	COMMONWEALTH EDISON CO	WTR/SWR 2.9.26-3.10.26	145.45	None
82-202-521902	WELL #2 2.9.26-3.10.26	COMMONWEALTH EDISON CO	WELL #2 2.9.26-3.10.26	42.78	None
82-202-522002	35 W HOME 2.4.26-3.5.26	NICOR GAS	35 W HOME 2.4.26-3.5.26	720.50	None
82-202-522002	31 W HOME 2.4.26-3.5.26	NICOR GAS	31 W HOME 2.4.26-3.5.26	181.24	None
82-202-522002	1260 S CORNELL 2.9.26-3.10	NICOR GAS	1260 S CORNELL 2.9.26-3.10.26	183.12	None
82-202-529202	WESTMORE & WISCONSIN PHASE	CIVILTECH ENGINEERING INC	WESTMORE & WISCONSIN PHASE 2 DE	254.72	None
82-202-529302	SEPTEMBER 2025 ROUTINE SAM	ETP LABS INC	SEPTEMBER 2025 ROUTINE SAMPLES	468.00	None
82-202-529302	OCTOBER 2025 ROUTINE MONTH	ETP LABS INC	OCTOBER 2025 ROUTINE MONTHLY SAMPLES	468.00	None
82-202-529302	NOVEMBER 2026 ROUTINE MONT	ETP LABS INC	NOVEMBER 2026 ROUTINE MONTHLY SAMPLES	468.00	None
82-202-539902	NUTS & BOLTS FOR STOCK	LAWSON PRODUCTS INC	NUTS & BOLTS FOR STOCK	351.88	None
Total Department 202 EQUIPMENT AND SUPPLIES				3,871.69	
Total Fund 82 WATER SUPPLY FUND				4,557.43	
Fund: 83 WASTEWATER FUND					
Department: 201 ADMINISTRATION					
83-201-521001	WIRELESS SERVICE FROM 01/2	VERIZON WIRELESS PW	WIRELESS SERVICE FROM 01/27/26 to 02/	2.52	None
83-201-521001	WIRELESS SERVICE FROM 01/2	VERIZON WIRELESS PW	WIRELESS SERVICE FROM 01/27/26 to 02/	72.06	None

INVOICE DISTRIBUTION REPORT FOR VILLAGE OF VILLA PARK

EXP CHECK RUN DATES 03/30/2026 - 03/30/2026

POSTED AND UNPOSTED

OPEN AND PAID

GL Number	Invoice Line Desc	Vendor Name	Invoice Description	Amount	Check Number
Fund: 83 WASTEWATER FUND					
Department: 201 ADMINISTRATION					
83-201-521001	WIRELESS SERVICE FROM 01/2	VERIZON WIRELESS PW	WIRELESS SERVICE FROM 01/27/26 to 02/	38.07	None
83-201-527001	COPIER USAGE 3.5-4.4.26	GORDON FLESCH CO. INC	COPIER USAGE 3.5-4.4.26	211.24	None
83-201-529901	4TH QTR STAFF RANDOM TESTI	ELMHURST OCCUPATIONAL HEAL	4TH QTR STAFF RANDOM TESTING	271.00	None
83-201-529901	NEW HIRE DRUG SCREENING	ELMHURST OCCUPATIONAL HEAL	NEW HIRE DRUG SCREENING	63.00	None
Total Department 201 ADMINISTRATION				657.89	
Department: 202 EQUIPMENT AND SUPPLIES					
83-202-521902	WESTLANDS LIFT STN 2.11.26	COMMONWEALTH EDISON CO	WESTLANDS LIFT STN 2.11.26-3.12.26	56.94	None
83-202-521902	NORTH & YALE 1.29.26-2.27.	COMMONWEALTH EDISON CO	NORTH & YALE 1.29.26-2.27.26	922.77	None
83-202-521902	900 N VILLA 1.29.26-2.27.2	COMMONWEALTH EDISON CO	900 N VILLA 1.29.26-2.27.26	718.18	None
83-202-521902	RT 83 LIFT STN 2.11.26-3.1	COMMONWEALTH EDISON CO	RT 83 LIFT STN 2.11.26-3.12.26	66.16	None
83-202-521902	YALE/RIDGE LIFT STN 2.11.2	COMMONWEALTH EDISON CO	YALE/RIDGE LIFT STN 2.11.26-3.12.26	73.41	None
83-202-522002	149 S MONTEREY 2.4.26-3.5.	NICOR GAS	149 S MONTEREY 2.4.26-3.5.26	812.90	None
83-202-522002	820 N YALE 2.4.26-3.5.26	NICOR GAS	820 N YALE 2.4.26-3.5.26	65.07	None
83-202-522002	889 W NORTH 2.5.26-3.6.26	NICOR GAS	889 W NORTH 2.5.26-3.6.26	64.45	None
83-202-522002	890 N VILLA 2.4.26-3.5.26	NICOR GAS	890 N VILLA 2.4.26-3.5.26	92.08	None
83-202-529202	WESTMORE & WISCONSIN PHASE	CIVILTECH ENGINEERING INC	WESTMORE & WISCONSIN PHASE 2 DE	262.31	None
Total Department 202 EQUIPMENT AND SUPPLIES				3,134.27	
Department: 204 CONTRACTUAL SERVICES					
83-204-529204	WESTMORE & WISCONSIN PHASE	CIVILTECH ENGINEERING INC	WESTMORE & WISCONSIN PHASE 2 DE	1,399.01	None
Total Department 204 CONTRACTUAL SERVICES				1,399.01	
Total Fund 83 WASTEWATER FUND				5,191.17	

INVOICE DISTRIBUTION REPORT FOR VILLAGE OF VILLA PARK

EXP CHECK RUN DATES 03/30/2026 - 03/30/2026
 POSTED AND UNPOSTED
 OPEN AND PAID

GL Number	Invoice Line Desc	Vendor Name	Invoice Description	Amount	Check Number
--- TOTALS BY FUND ---					
10			CORPORATE FUND	648,386.36	
11			CAPITAL / BUILDING & LAND IMPROVE FUN	331,033.55	
26			TIF 6 FUND-NO ARDMORE/VERMONT	1,350.00	
32			MFT FUND	12,747.98	
35			RECREATION FUND	2,261.65	
36			PARKS FUND	1,025.58	
41			SWIMMING POOL & REC FUND	563.77	
60			STREET IMPROVEMENT FUND	34,054.85	
65			EQUIPMENT REPLACEMENT FUND	924.95	
82			WATER SUPPLY FUND	4,557.43	
83			WASTEWATER FUND	5,191.17	
Total For All Funds:				1,042,097.29	

[Handwritten signature]

[Handwritten signature] 3-30-26

**BILL LISTING TO BE PRESENTED TO
THE VILLAGE BOARD OF TRUSTEES
ON 4.13.26 CY WEEKLY CHECK RUN
DATED 4.6.26**

INVOICE DISTRIBUTION REPORT FOR VILLAGE OF VILLA PARK
EXP CHECK RUN DATES 04/06/2026 - 04/06/2026
POSTED AND UNPOSTED
OPEN AND PAID

GL Number	Invoice Line Desc	Vendor Name	Invoice Description	Amount	Check Number
Fund: 10 CORPORATE FUND					
Department: 121 INFORMATION TECHNOLOGY					
10-121-529901	LABOR FOR SERVER VIRTUALIZ HEARTLAND BUSINESS SYSTEMS		LABOR FOR SERVER VIRTUALIZATION MIGRA	15,015.00	None
Total Department 121 INFORMATION TECHNOLOGY				15,015.00	
Department: 130 FINANCE					
10-130-529900	OTHER CONTRACTUAL SERVICES LAUTERBACH & AMEN LLP		SERVICES RENDERED - AUDIT DEC 31, 202	25,600.00	None
10-130-529900	OTHER CONTRACTUAL SERVICES LAUTERBACH & AMEN LLP		SERVICES RENDERED - DEC 31, 2024 SING	5,200.00	None
Total Department 130 FINANCE				30,800.00	
Department: 140 COMMUNITY DEVELOPMENT					
10-140-522400	PERMIT FEE REIMBURSEMENT	THOMAS BLASZAK	HOMEFLOOD PREVENTION PROGRAM - 1126 S	250.00	None
Total Department 140 COMMUNITY DEVELOPMENT				250.00	
Department: 150 CENTRAL SERVICES					
10-150-521000	PHONE SERVICE DATES 3.1.26	GRANITE TELECOMMUNICATIONS	PHONE SERVICE DATES 3.1.26-3.31.26	1,390.63	None
10-150-527000	COPIER USAGE 4.5.26-5.4.26	GORDON FLESCH CO. INC	COPIER USAGE 4.5.26-5.4.26	3,084.09	None
10-150-529900	2025 ACA & 1095 FORMS	SIKICH LLP	2025 ACA & 1095 FORMS	7,459.44	None
Total Department 150 CENTRAL SERVICES				11,934.16	
Department: 160 BUILDINGS & GROUNDS					
10-160-522300	MUSEUM	SALT CREEK SANITARY DISTRI	MUSEUM	20.25	None
10-160-522300	FIRE #81	SALT CREEK SANITARY DISTRI	FIRE #81	252.71	None
10-160-522300	LUFKIN PARK	SALT CREEK SANITARY DISTRI	LUFKIN PARK	16.00	None
10-160-522300	JEFF POOL	SALT CREEK SANITARY DISTRI	JEFF POOL	18.76	None
10-160-522300	JEFF POOL FLTR	SALT CREEK SANITARY DISTRI	JEFF POOL FLTR	16.00	None
10-160-522300	FIRE #82	SALT CREEK SANITARY DISTRI	FIRE #82	178.83	None
10-160-522300	PW STORAGE BLDG	SALT CREEK SANITARY DISTRI	PW STORAGE BLDG	16.00	None
10-160-522300	VILLAGE HALL	SALT CREEK SANITARY DISTRI	VILLAGE HALL	84.59	None
10-160-522300	PARKS GARAGE	SALT CREEK SANITARY DISTRI	PARKS GARAGE	605.00	None
10-160-522300	PW GARAGE	SALT CREEK SANITARY DISTRI	PW GARAGE	31.50	None
10-160-522300	VEH MAINT	SALT CREEK SANITARY DISTRI	VEH MAINT	70.25	None
10-160-522300	CENTRAL PUMP STATION	SALT CREEK SANITARY DISTRI	CENTRAL PUMP STATION	118.62	None
10-160-522300	PUBLIC WORKS	SALT CREEK SANITARY DISTRI	PUBLIC WORKS	116.75	None
10-160-522300	POLICE STATION	SALT CREEK SANITARY DISTRI	POLICE STATION	205.34	None
Total Department 160 BUILDINGS & GROUNDS				1,750.60	
Department: 170 COMMUTER PARKING LOT					
10-170-522301	METRA STN	SALT CREEK SANITARY DISTRI	METRA STN	144.55	None
Total Department 170 COMMUTER PARKING LOT				144.55	
Department: 180 GARAGE					
10-180-530900	DIESEL FUEL PURCHASE 1,400	AL WARREN OIL COMPANY INC	DIESEL FUEL PURCHASE 1,400 GALLONS	5,673.78	None
10-180-530900	GASOLINE FUEL PURCHASE 5,5	AL WARREN OIL COMPANY INC	GASOLINE FUEL PURCHASE 5,502 GALLONS	18,398.70	None
Total Department 180 GARAGE				24,072.48	
Department: 207 POLICE-RECORDS					
10-207-520207	TRAINING & CONFERENCES	FBI-LEEDA INC	ELI CLASS-ROSEMONT-PAGAN	795.00	None
10-207-521000	EMPLOYEE CELL	VERIZON WIRELESS	EMPLOYEE CELL	2,513.01	None
10-207-526301	POST RETIREMENT BENEFIT AP	BREGMAN, MARC	POST RETIREMENT BENEFIT APRIL 2026	125.00	None
10-207-526301	POST RETIREMENT BENEFIT AP	MCMAMARA, JAMES J	POST RETIREMENT BENEFIT APRIL 2026	125.00	None
10-207-526301	POST RETIREMENT BENEFIT AP	SUBJECT, DAVID	POST RETIREMENT BENEFIT APRIL 2026	125.00	None
10-207-526301	POST RETIREMENT BENEFITS A	SHERRY, JAMES	POST RETIREMENT BENEFIT APRIL 2026	125.00	None
10-207-529900-OCS019	TOWER DUMP-VPPC2502303	AT&T (subpo)	TOWER DUMP-VPPC2502303	120.00	None

INVOICE DISTRIBUTION REPORT FOR VILLAGE OF VILLA PARK

EXP CHECK RUN DATES 04/06/2026 - 04/06/2026

POSTED AND UNPOSTED

OPEN AND PAID

GL Number	Invoice Line Desc	Vendor Name	Invoice Description	Amount	Check Number
Fund: 10 CORPORATE FUND					
Department: 207 POLICE-RECORDS					
10-207-529900-OCS019	CREDIT CHECK - VPPC2500869	FIFTH THIRD BANK LEGAL ENT	CREDIT CHECK - VPPC2500869	25.00	None
10-207-531700	TONER FOR COPIER	GORDON FLESCH CO. INC	TONER FOR COPIER-SURCHARGE	22.50	None
10-207-532009	MEDICATION - K-9 LUKE	PARTNERS AND PAWS VETERINA	MEDICATION - K-9 LUKE	25.56	None
10-207-532009	MEDICATION - K-9 LUKE	PARTNERS AND PAWS VETERINA	MEDICATION - K-9 LUKE	170.68	None
Total Department 207 POLICE-RECORDS				4,171.75	
Department: 211 FIRE					
10-211-526301	POST RETIREMENT BENEFIT AP BARTON, MICHAEL		POST RETIREMENT BENEFIT APRIL 2026	125.00	None
10-211-526301	POST RETIREMENT BENEFIT AP BICKLEY, JAMES		POST RETIREMENT BENEFIT APRIL 2026	125.00	None
10-211-526301	POST RETIREMENT BENEFIT AP BLASKOVICH, ERIC		POST RETIREMENT BENEFIT APRIL 2026	125.00	None
10-211-526301	POST RETIREMENT BENEFIT AP SPARGER, JEFFREY		POST RETIREMENT BENEFIT APRIL 2026	125.00	None
10-211-529901	DOOR REPAIR 311 N. ARDMORE	VILLA PARK ACE HARDWARE	DOOR REPAIR 311 N. ARDMORE 26-0556	62.62	None
Total Department 211 FIRE				562.62	
Department: 251 PUBLIC WORKS					
10-251-527001	COPIER USAGE 4.5.26-5.4.26	GORDON FLESCH CO. INC	COPIER USAGE 4.5.26-5.4.26	211.24	None
Total Department 251 PUBLIC WORKS				211.24	
Total Fund 10 CORPORATE FUND				88,912.40	
Fund: 32 MFT FUND					
Department: 202 EQUIPMENT AND SUPPLIES					
32-202-521925	UTILITY - ELECTRIC	CONSTELLATION NEWENERGY IN 0 E WISCONSIN;	1.13.26-2.11.26	9,918.96	None
32-202-521925	UTILITY - ELECTRIC	CONSTELLATION NEWENERGY IN 118 S VILLA AVE;	1.13.26-2.11.26	63.19	None
32-202-521925	UTILITY - ELECTRIC	CONSTELLATION NEWENERGY IN 1 S CENTRAL LITE RT/25;	1.13.26-2.11.	482.97	None
32-202-534127	BULK SAFE-T-SALT	MORTON SALT INC	BULK SAFE-T-SALT	7,356.39	None
32-202-534226	HIGH PERFORMANCE COLD PATC	DUPAGE MATERIALS COMPANY L	HIGH PERFORMANCE COLD PATCH	320.00	None
32-202-534226	HIGH PERFORMANCE COLD PATC	DUPAGE MATERIALS COMPANY L	HIGH PERFORMANCE COLD PATCH	400.00	None
32-202-534226	HIGH PERFORMANCE COLD PATC	DUPAGE MATERIALS COMPANY L	HIGH PERFORMANCE COLD PATCH	320.00	None
Total Department 202 EQUIPMENT AND SUPPLIES				18,861.51	
Total Fund 32 MFT FUND				18,861.51	
Fund: 35 RECREATION FUND					
Department: 201 ADMINISTRATION					
35-201-521001	PHONE SERVICE DATES 3.1.26	GRANITE TELECOMMUNICATIONS	PHONE SERVICE DATES 3.1.26-3.31.26	327.10	None
35-201-527001	COPIER USAGE 4.5.26-5.4.26	GORDON FLESCH CO. INC	COPIER USAGE 4.5.26-5.4.26	337.98	None
35-201-527001	COPIER USAGE 4.5.26-5.4.26	GORDON FLESCH CO. INC	COPIER USAGE 4.5.26-5.4.26	307.16	None
Total Department 201 ADMINISTRATION				972.24	
Department: 216 PRP-BLDG & GROUNDS					
35-216-522316	VPRC	SALT CREEK SANITARY DISTRI	VPRC	382.68	None
35-216-522316	ROTARY PK RESTROOMS	SALT CREEK SANITARY DISTRI	ROTARY PK RESTROOMS	16.00	None
35-216-522316	ICC	SALT CREEK SANITARY DISTRI	ICC	1,023.71	None
Total Department 216 PRP-BLDG & GROUNDS				1,422.39	
Department: 235 PROGRAMS					
35-235-529735	CY26 OFFICIATING SERVICES	OFFICIAL FINDERS LLC	CY26 OFFICIATING SERVICES WOMEN'S VOL	120.00	None
35-235-529735	CY26 OFFICIATING SERVICES	OFFICIAL FINDERS LLC	CY26 OFFICIATING SERVICES WINTER BASK	800.00	None
35-235-529735	WINTER BASKETBALL REFEREES	LOMBARD PARK DISTRICT	WINTER BASKETBALL REFEREES	1,120.00	None
35-235-529935	OTHER CONTRACTUAL SERVICES	TUMBLING TIMES INC	CY26 CONTRACTUAL GYMNASTICS INSTRUCTI	2,639.00	None
35-235-531135	SENIOR LETS DO LUNCH CARRY	MICHAEL ANTHONY'S PIZZA	SENIOR LETS DO LUNCH CARRYOUT 3/19/26	170.00	None

INVOICE DISTRIBUTION REPORT FOR VILLAGE OF VILLA PARK

EXP CHECK RUN DATES 04/06/2026 - 04/06/2026

POSTED AND UNPOSTED
OPEN AND PAID

GL Number	Invoice Line Desc	Vendor Name	Invoice Description	Amount	Check Number	
Fund: 35 RECREATION FUND						
Department: 235 PROGRAMS						
				Total Department 235 PROGRAMS	4,849.00	
				Total Fund 35 RECREATION FUND	7,243.63	
Fund: 36 PARKS FUND						
Department: 201 ADMINISTRATION						
36-201-521001	PHONE SERVICE DATES 3.1.26	GRANITE TELECOMMUNICATIONS	PHONE SERVICE DATES 3.1.26-3.31.26	59.30	None	
36-201-522301	THE DEPOT	SALT CREEK SANITARY DISTRI	THE DEPOT	21.39	None	
36-201-522301	N TERR PARK	SALT CREEK SANITARY DISTRI	N TERR PARK	23.75	None	
36-201-522301	TWIN LAKES	SALT CREEK SANITARY DISTRI	TWIN LAKES	16.02	None	
36-201-522301	PK GARAGE #2	SALT CREEK SANITARY DISTRI	PK GARAGE #2	39.48	None	
36-201-527001	COPIER USAGE 4.5.26-5.4.26	GORDON FLESCH CO. INC	COPIER USAGE 4.5.26-5.4.26	168.99	None	
				Total Department 201 ADMINISTRATION	328.93	
				Total Fund 36 PARKS FUND	328.93	
Fund: 41 SWIMMING POOL & REC FUND						
Department: 301 POOL&REC-ADMIN						
41-301-521001	PHONE SERVICE DATES 3.1.26	GRANITE TELECOMMUNICATIONS	PHONE SERVICE DATES 3.1.26-3.31.26	55.47	None	
				Total Department 301 POOL&REC-ADMIN	55.47	
				Total Fund 41 SWIMMING POOL & REC FUND	55.47	
Fund: 50 DEBT SERVICE FUND						
Department: 290 STORM SEWER SEPARATION						
50-290-569090	PRINCIPL PAYMENTS--SERIES 2 US BANK		04120 PAYING AGENT - ADMIN FEES	600.00	None	
				Total Department 290 STORM SEWER SEPARATION	600.00	
				Total Fund 50 DEBT SERVICE FUND	600.00	
Fund: 82 WATER SUPPLY FUND						
Department: 201 ADMINISTRATION						
82-201-521001	PHONE SERVICE DATES 3.1.26	GRANITE TELECOMMUNICATIONS	PHONE SERVICE DATES 3.1.26-3.31.26	40.17	None	
82-201-527001	COPIER USAGE 4.5.26-5.4.26	GORDON FLESCH CO. INC	COPIER USAGE 4.5.26-5.4.26	211.24	None	
				Total Department 201 ADMINISTRATION	251.41	
Department: 202 EQUIPMENT AND SUPPLIES						
82-202-521902	CORNELL PUMP STATION; 1.13	CONSTELLATION NEWENERGY IN	CORNELL PUMP STATION; 1.13.26-2.11.26	2,630.91	None	
82-202-522302	WTR/SWR	SALT CREEK SANITARY DISTRI	WTR/SWR	52.24	None	
				Total Department 202 EQUIPMENT AND SUPPLIES	2,683.15	
				Total Fund 82 WATER SUPPLY FUND	2,934.56	
Fund: 83 WASTEWATER FUND						
Department: 201 ADMINISTRATION						
83-201-521001	PHONE SERVICE DATES 3.1.26	GRANITE TELECOMMUNICATIONS	PHONE SERVICE DATES 3.1.26-3.31.26	40.17	None	
83-201-527001	COPIER USAGE 4.5.26-5.4.26	GORDON FLESCH CO. INC	COPIER USAGE 4.5.26-5.4.26	211.24	None	
				Total Department 201 ADMINISTRATION	251.41	
Department: 202 EQUIPMENT AND SUPPLIES						
83-202-521902	WWFTF; 1.13.26-2.11.26	CONSTELLATION NEWENERGY IN	WWFTF; 1.13.26-2.11.26	2,405.53	None	
83-202-540102	HOMEFLOOD PREVENTION PROGR	THOMAS BLASZAK	HOMEFLOOD PREVENTION PROGRAM - 1126 S	1,062.50	None	
				Total Department 202 EQUIPMENT AND SUPPLIES	3,468.03	

INVOICE DISTRIBUTION REPORT FOR VILLAGE OF VILLA PARK

EXP CHECK RUN DATES 04/06/2026 - 04/06/2026

POSTED AND UNPOSTED

OPEN AND PAID

GL Number	Invoice Line Desc	Vendor Name	Invoice Description	Amount	Check Number
Fund: 83 WASTEWATER FUND					
Total Fund 83 WASTEWATER FUND				3,719.44	



INVOICE DISTRIBUTION REPORT FOR VILLAGE OF VILLA PARK

EXP CHECK RUN DATES 04/06/2026 - 04/06/2026

POSTED AND UNPOSTED
OPEN AND PAID

GL Number	Invoice Line Desc	Vendor Name	Invoice Description	Amount	Check Number
--- TOTALS BY FUND ---					
		10	CORPORATE FUND	88,912.40	
		32	MFT FUND	18,861.51	
		35	RECREATION FUND	7,243.63	
		36	PARKS FUND	328.93	
		41	SWIMMING POOL & REC FUND	55.47	
		50	DEBT SERVICE FUND	600.00	
		82	WATER SUPPLY FUND	2,934.56	
		83	WASTEWATER FUND	3,719.44	
		Total For All Funds:		122,655.94	

Miss Lisa

Drawn 3-31-26

Village of Villa Park Board of Trustees

Meeting Minutes – March 23, 2026

Date: March 23, 2026

Time: Meeting called to order at 7:00 PM

Location: Village of Villa Park

20 S. Ardmore Avenue

Village Hall, Boardroom

Villa Park, IL 60181

1. Call to Order & Roll Call

- The meeting was called to order by President Patrick. Clerk Rolf Laukant performed the roll call.
 - a. **Present:** Trustees Cari Alfano, Jorge Cordova, Tina Konstatos, Jack Kozar, Khalid Sabri, Deepa Kumar, and President Patrick
- A quorum was established.

2. Pledge of Allegiance

- Attendees stood for the Pledge of Allegiance.

3. Amendments to the Agenda

Trustee Kozar made a motion to move Executive Session up to after the Consent Agenda (9d) and seconded by Trustee Konstatos.

Discussion ensued as to what items would be discussed. President Patrick suggested that they go with that motion and they can go back into Executive Session if needed.

Roll Call Vote:

Ayes: Trustees Alfano, Cordova, Konstatos, Kozar, Kumar, Sabri

Nays: None

4. Public Comments on Agenda Items

Cheryl Tucker: First thanked the Board for the staff reports
Item 10a – concerned that the water main replacement is not included and will be added before the road repair.
Item 10e – Budget Items – questioned where the cannabis tax is being applied and discrepancies on another line item
Item 12a – asked to have someone explain how it works with the food and drink ratio and the rules for Class E holders clarified. Also, will Mortadeli still have outdoor seating and packaged liquor to go.
Item 14d – Hope that the discount on the passes is not only for baseball families, but for all families.

- Nick Cuzzone:** Item 12a – Urge the Board to pass this ordinance and discussion about clarification about the 50% food and liquor ratio
- David Holston:** Item 13d – I am the pastor of Christian Church of Villa Park and am asking that the Board approve the special use request to move to the St. Charles Road location
- Doris Carter:** Item 13d – asking for approval of the special use
- Nick Staniford:** Item 16a – Zoning attorney for Shane Bank. Pointed out a few things in the letter provided to the Board asking for the RDA to be amended to provide new dates. Working with SB Friedman could slow down the project completion
- Anthony Oddo:** Parking on Villa issue that was discussed at the Plan Commission. Please consider short term parking before it gets on the agenda.
- Dr. Vish:** Item 16a – please allow us to proceed. Reiterate that we have full financing. Please let us proceed with this project.

5. Public Comments on Non-Agenda Items

None

6. Proclamations

- a. Proclamation Recognizing March 23-27, 2026 as Municipal Finance Appreciation Week

7. Presentation

None

8. Appointment to Commission

None

9. Consent Agenda

- a. Bill Listings for the weeks of March 9, 2026 in the amount of \$30,218.97 and March 16, 2026 in the amount of \$974,338.86.
- b. Approval of the Minutes of Committee of the Whole Meeting and The Village Board of Trustees Meeting held on March 9, 2026.
- c. Resolution for the use of Motor Fuel Tax for General Street Maintenance Section 26-00000-00-GM
The Village utilizes Motor Fuel Tax (MFT) funds to help fund the general maintenance activities on the Village roadways for the cost of personnel and materials. This includes the purchase of salt, gravel, asphalt materials, sign materials, and roadway paint for crosswalks, along with the portion of the cost of personnel and equipment to perform MFT qualified work. The approved FY26 Budget has planned MFT expenditures of \$364,000 for general maintenance; this resolution is required to use those funds.
- d. Resolution of the Village of Villa Park, DuPage County, Illinois Authorizing and Approving an Agreement with Robe, Inc. for the Restroom Renovation Project at the Parks Maintenance Facility

Motion to approve consent agenda made by Trustee Kozar and seconded by Trustee Konstatos.

No Discussion

Roll Call Vote:

Ayes: Trustees Alfano, Cordova, Konstatos, Kozar, Kumar, Sabri

Nays: None

Motion Passed

Motion to move into Executive Session made by Trustee Konstatos and seconded by Trustee Kozar for the following:

- a. Pursuant to 5 ILCS 120/2(c)(1), the appointment, employment, compensation, discipline, performance, or dismissal of specific employees of the public body or legal counsel for the public body.
- b. Pursuant to 5ILCS 120/2 (c) (11) regarding litigation, when action against, affecting or on behalf of the Village has been filed and is pending before a court or when the Village finds that an action is probable or imminent.

Roll Call Vote:

Ayes: Trustees Alfano, Cordova, Konstatos, Kozar, Kumar, Sabri

Nays: None

Move to Executive Session at 7:29 p.m.

Reconvene to Board Meeting at 8:40 p.m.

Roll Call Vote:

Ayes: Trustees Alfano, Cordova, Konstatos, Kozar, Kumar, Sabri

Nays: None

10. Staff Reports

- a. FOIA Summary Report Feb. 2026 and FOIA requests Feb. 2026
- b. Gaming Report February 2026
- c. Community & Economic Development - February 2026 Report
- d. Public Work/Parks Capital Projects Update (Feb 2026)
- e. February 2026 Revenue and Expense Report as of 3-19-2026

No Discussion

11. Ordinance for First Reading

None

12. Ordinance for Second Reading

- a. An Ordinance Amending Section 3-313(A) of the Municipal Code of the Village of Villa Park, DuPage County, Illinois Decreasing the Number of Class AAA Liquor Licenses and Increasing the Number of Class I Liquor Licenses
This ordinance would adjust the number of liquor licenses available with the AAA and I classifications. This is a second reading. The Liquor Control Commission recommends approval.

Motion to approve ordinance made by Trustee Cordova and seconded by Trustee Kumar.

Discussion began with asking for an explanation of requirements in terms of food sales. Village Attorney Morton explained that food/gaming has to be more than 50% of total gross receipts and liquor less than 50% of total gross receipts to be considered a restaurant. Without that, it does not qualify for a Class I license. Trustee Cordova asked to confirm that food and game revenue total gross receipts can include gaming. Trustee Kumar is concerned about these businesses just having gaming to satisfy that. Attorney Morton explained that the license can be changed to read just food. This would be good for anyone that is classified a restaurant. Amendments would go before the Liquor Commission and then come before the Board. Trustee Konstatos stated that our liquor licenses are a mess and they need to be relooked at and rewritten. We need a clean process. President Patrick stated that the Local Liquor Commission is new. It is on the radar and we are looking at all the aspects and processes. He is asking for everyone to give them time. Trustee Alfano asked if the work has started and if so, where it is at? Further discussion took place regarding the outline of each license and that the criteria needs to be met. It was explained that the parameters of a license stay with that license until it is renewed, and then any new rules apply. Trustee Kozar agrees with Trustee Konstatos and Trustee Kumar that these things should be fixed before we issue any more licenses. We keep adding licenses – is that in the best interest of Villa Park? President Patrick suggested that everyone send an email to the Liquor Control Commission with what you would like to see.

Roll Call Vote:

Ayes: Trustees Cordova, Kumar

Nays: Trustees Alfano, Konstatos, Kozar, Sabri

Ordinance Did Not Pass

13. Ordinances

- a. Ordinance Authorizing the Sale of Debt Certificates for the Approved Purchase of Village Vehicles (Three Squads and One Dump Truck) Not to Exceed \$463,750.00.
This ordinance formalizes the Board's recent approval of the purchase and financing of four vehicles by issuing debt certificates. Staff recommends approval.

Motion to approve ordinance made by Trustee Konstatos and seconded by Trustee Sabri.

Trustee Cordova asked where the money is coming from. Director Mika explained that there is budgeted \$75,000 in the equipment replacement fund and the 3 year loan for \$83,000 is part of the amended budget.

Roll Call Vote:

Ayes: Trustees Alfano, Cordova, Konstatos, Kozar, Kumar and Sabri

Nays: None

Ordinance Passed

- b. An Ordinance Adopting An Amended Budget For the Village of Villa Park, County of DuPage, State of Illinois For All Corporate Purposes, in Lieu of an Annual Appropriation Ordinance, For the Fiscal Year Commencing on January 1, 2025 and Ending on December 31, 2025.

No Discussion

Roll Call Vote:

Ayes: Trustees Alfano, Cordova, Konstatos, Kozar, Kumar and Sabri

Nays: None

Ordinance Passed

- c. An Ordinance Adopting an Amended Budget for the Village of Villa Park, County of DuPage, State of Illinois for all Corporate Purposes, in Lieu of an Annual Appropriation Ordinance, for the Fiscal Year Commencing on January 1, 2026 and Ending on January 31, 2026.

Motion to approve ordinance made by Trustee Kumar and seconded by Trustee Konstatos

Discussion ensued regarding the \$13M deficit and where the funds will come from. Director Mika stated that a 5 year budget plan will be come.

Motion to revisit this 2026 budget and make necessary revisions to cut the deficit by \$2M and to provide the board with an update in 30 days was made by Trustee Alfano and seconded by Trustee Kumar.

Trustee Cordova asked where the revenue has fallen off and what will it look like since we have said no to 14 gaming places and any loss of revenue. Trustee Konstatos wants to see more than \$2M cut from the budget. Trustee Alfano asked where are the increases in spending. Trustee Kumar discussed the TIF budgets also. Trustee Konstatos stated we are sending the wrong message that we only care about bars and gaming. What about other businesses in town.

Chief Kubish asked about 2 officers ready to be hired that are not in the budget. The PD is down 2 people right now. Manager Rivas stated that we need to keep the numbers up so we should move forward with these two people. Attorney Morton recommended the ordinance be limited to that change. Trustee Kumar stated that department heads need to be more careful when creating their budgets and make sure nothing is left out. President Patrick commended Director Mika's work and how she has been a tremendous asset to the Village. Thank you for all you are doing. Thank you to Chief Kubish. Trustee Kozar commented that the scolding that Trustee Kumar gave was inappropriate. He respects Trustee Alfano's cause to cut the budget, but this should be in a COW or a line item on the agenda. He disagrees with cutting the budget now. Do it later and have suggestions presented.

Quite a bit of discussion ensued regarding reviewing the budget and how staff is involved.

Call to Question made by Trustee Alfano and seconded by Trustee Konstatos.

Roll Call Vote:

Ayes: Trustees Alfano, Cordova, Konstatos, Kozar, Kumar, Sabri, President Patrick

Nays: None

Motion to approve the amended budget for FY 12/31/2026 minus everything except \$195,407 for police salaries made by Trustee Kumar and seconded by Trustee Konstatos.

Roll Call Vote:

Ayes: Trustees Alfano, Cordova, Konstatos, Kumar, Sabri

Nays: Trustee Kozar

Motion Approved

Motion for our Village Manager, Finance Director and Department Heads to revisit the 2026 budget and make the necessary revisions to cut our deficit by \$2,000,000 total and to provide the board an update monthly made by Trustee Alfano and seconded by Trustee Kumar.

Manager Rivas explained that 30 days is not long enough with all the audits and day to day responsibilities. Director Mika stated that they have hit a road block on the 2025 audit and other issues we have come across, which were explained in detail by Mika. I can't give you a definite answer as far as a timeline. Rivas suggested that they will address this issue with each department head at their weekly department head meetings. We need to assist finance.

Roll Call Vote:

Ayes: Trustees Alfano, Cordova, Konstatos, Kumar, Sabri

Nays: Trustee Kozar

Motion Passed

- d. An Ordinance of the Village of Villa Park, DuPage County, Illinois, Granting Special Uses for Religious Assembly Use and a Drive-In/Drive-Through Facility Use for the Property Located at 507 E. St. Charles Road.

This Ordinance approves Petition ZBA-25-12 for a Special Use from Section 6.1.1 Use Table to permit Religious Assembly and Drive-in/Drive-through Facility uses within the existing multi-tenant building at 501-507 E. St. Charles Road. The Zoning Board of Appeals recommended approval by a vote of 5-1-1.

Motion for the ordinance made by Trustee Cordova and seconded by Trustee Konstatos.

Trustee Kumar asked where this location is. She asked what this is for and where it is. She stated it doesn't feel like this is a good fit. Director House explained the relocation due to the church selling their property and renting back some space. That space is now too small. This is larger.

Motion to table this to the next meeting was made by Trustee Kumar and seconded by Trustee Konstatos.

President Patrick explained that they would lease the location. A new development there would be up to the owner of the property. Trustee Kozar asked that if they are leasing the property to the church, does that change the obligation of the building owner to pay taxes in the same way they are paying taxes now, since this is a not-for-profit religious assembly. Director House stated that the taxes would stay the same. Trustee Kozar stated that this is a noble cause and our opportunity to be a responsible steward. President Patrick stated that the board has had time to review the information in the packet. Trustee Konstatos asked about traffic. Director House explained a traffic study was done. There is no traffic impact. She also asked the pastor about their helping the homeless people and seniors.

Trustee Kumar and Trustee Konstatos rescinded their motion.

Trustee Alfano asked staff to look at the condition of the privacy fence on the property. Pastor explained that the food pantry hours are one day a week. He was asked if they are looking for volunteers. He stated they would love to have people volunteer. President Patrick thanked them for giving back to the community for all these years.

Roll Call Vote:

Ayes: Trustee Alfano, Cordova, Konstatos, Kozar, Kumar, Sabri. President Patrick

Nays: None

Ordinance Passed

14. Resolutions

- a. Resolution of the Village of Villa Park, DuPage County, Illinois, Providing for the Selection of Qualified Consulting Firms to Provide Construction Engineering Services for Capital Improvement Projects

Motion to approve resolution made by Trustee Konstatos and seconded by Trustee Alfano

No Discussion

Roll Call Vote:

Ayes: Trustees Alfano, Cordova, Konstatos, Kozar, Kumar, Sabri

Nays: None

- b. Resolution of the Village of Villa Park, DuPage County, Illinois, Providing for the Selection of Qualified Consulting Firms to Provide Preliminary and Design Engineering Services for Capital Improvement Projects

Motion to approve resolution made by Trustee Konstatos and seconded by Trustee Alfano

No Discussion

Roll Call Vote:

Ayes: Trustees Alfano, Cordova, Konstatos, Kozar, Kumar, Sabri

Nays: None

- c. A Resolution of the Village of Villa Park, DuPage County, Illinois, Establishing the Membership Fees for the Villa Park Recreation Center for 2026

Motion to approve resolution made by Trustee Alfano and seconded by Trustee Konstatos

No Discussion

Roll Call Vote:

Ayes: Trustees Alfano, Cordova, Konstatos, Kozar, Kumar, Sabri

Nays: None

- d. A Resolution of the Village of Villa Park, DuPage County, Illinois, Establishing the Pool Fees for the Village's Swimming Pool for 2026.

Motion to approve resolution made by Trustee Alfano and seconded by Trustee Konstatos

Trustee Kumar questioned the discounted fees. Sue Earl explained that after July 4th, several pools offer a discounted membership. Last year, we sold one pass after July 4th. Trustee Kumar stated we should have an analysis of what it would look like if we do reduce our revenue. President Patrick explained that pools are not money makers. Trustee Alfano stated that there is data in the packet. She believes it is relatively flat. This is the first year we are doing this, we don't have that data on that. Sue Earl stated that she thinks people will do it. Manager Rivas said that it is shown in the packet that other towns have done this. He thinks we should try it. Trustee Kumar suggested that they should think about getting sponsorships to bring in more revenue. The pool will need repairs. President Patrick reiterated that the pool is not about making money. It is an amenity and it is just for the need of our residents. Trustee Alfano mentioned that the Community Recreation Commission has discussed sponsorships and discussion about a new pool. Trustee Konstatos suggested they try it for a year. Trustee Kumar pointed out that she is not talking about profit, just revenue. She expressed that they are two different things. Trustee Cordova ask about any pool pass increases. Sue Earl confirmed there are no increases in the pass prices, only reduced daily fees for seniors and veterans. And now they would like to offer a 40% discount on late season passes purchased after July 4th.

Roll Call Vote:

Ayes: Trustees Alfano, Cordova, Konstatos, Kozar, Kumar, Sabri

Nays: None

15. Unfinished Business

Trustee Kumar asked how much the Village has paid Baker Tilly so far. Director Mika stated what she thought it might be, but agreed to get that information and email it to the Board.

16. New Business

- a. Resolution of the Village of Villa Park, DuPage County, Illinois, Authorizing and Approving an Agreement with SB Friedman Development Advisors, LLC for Services Related to Proposed Development at 403 N. Ardmore (HawthorneWorld).

Attorney Morton explained that the developer has a PUD that was recommended for approval by the Zoning Board of Appeals. They are also requesting a new RDA. Mr. Staniford stated a problem with SB Friedman's proposal about additional financial support. This proposal was based on conversations. SB Friedman has not yet looked at the RDA or any numbers. SB Friedman will look at finances of the developer and determine if this is something that is feasible or of interest to the Board. They will make sure there is enough funding. The developer has already received \$5.5 million in TIF reimbursement, mostly for property acquisitions and soft expenses. They are asking to reestablish the RDA from 2021 and still looking for additional funds under the TIF act. If the Board is considering a new RDA, it is recommended that the Village contract with SB Friedman so the terms of the RDA make financial sense for the Village.

Motion for resolution to be discussed without voting made by
Trustee Konstatos and seconded by Trustee Kozar.

Trustee Konstatos asked if the PUD allows what they are building, while the RDA is for the TIF dollars. Attorney Morton stated that the Village has received a lot of information from the developer including two financing arrangements which he explained. Trustee Konstatos asked if they are confirmed. Attorney Morton has not confirmed them yet but doesn't doubt them. Nothing is for sure until the closing. They are asking for an uncapped amount of TIF funds, but there are eligible and ineligible expenses that will be considered. Trustee Kumar questioned the loan to be used for HVAC portion of the project. Gerliga from the Han Group explained that the funds are mainly for high energy efficient systems but can be used for anything. Attorney Morton explained that SB Friedman will be providing a recommendation of what level of funding the Village would make sense to include in the RDA.

Trustee Konstatos asked if part of the money is going to be paying off existing loans. And, how much are the existing loans. Gerliga explained that the existing \$3 million loan will be paid off at closing. She stated there are no other loans. There is a PACE loan which is not a loan but an assessment. The Vaster loan will be paid back. Dr. Vish explained that the PACE loan is sitting in an escrow account. It is \$31 million at closing. The only expended money is for interest which has been \$4 million. Attorney Morton asked how the \$7 is in their budget. He responded that it was included in the \$87 million loan.

The Village parking lot will get released once Vaster is paid off. The foreclosure was settled and dismissed – the order was shared with the board a couple of times. Attorney Morton will verify receipt. Attorney Morton asked that based on the terms of the dismissal, could Mr. Staniford confirm the status of this. Staniford said it is not paid and will be paid off at closing. If the Village approves the zoning, Vaster will release the lien on the parking lot and the developer can return it to the Village. He stated that they just want the Village to approve zoning so they can proceed with the funding. SB Friedman will delay this. We need this zoning and PUD. The TIF is not a mandatory requirement to get this done. We have the funding. The terms of an RDA can come later. Dr. Vish stated that nothing gets paid back from the increment until the project is done. We just want the excess debt coverage back. Morton stated that that money is the Village's money.

Trustee Kumar asked if they can have a PUD without an RDA. Morton stated that the risk is dependent on the standards that we need to discuss later. Trustee Sabri asked if it is necessary to get into another contract. Just start with the PUD for now.

Trustee Konstatos and Trustee Kozar withdrew the motion. There is no motion.

b. Department Liaison Pilot Program

This idea is to have a department liaison program. For a 3-month period of time, each Board member will have the ability to have meetings with their assigned department head to understand their department and listen to anything they might have to say or ask about. The Board members can give a report at the second Board meeting of the month and talk about what is happening in that department. This is strictly voluntary.

Trustee Kumar stated her request, however, President Patrick said the first two 3-month periods have already been assigned. That list was emailed to each Board member. Trustee Konstatos is excited about this and would also like to get a tour of each facility and learn their day to day processes. Thank you Chief Kubish for the idea. Trustee Alfano thinks this is a great idea and sees value in this and the idea of rotating Board members and departments.

17. Village Commission Reports

- a. Minutes of the F.U.N. Commission Meeting held on January 27, 2026.
- b. Minutes of the Community Recreation Commission Meeting held on January 28, 2026.
- c. Villa Fest Subcommittee Report/Request

Trustee Alfano mentioned that the Chair of the Villa Fest Subcommittee wanted to know what the budget is or if there even is a budget. Manager Rivas stated he will check and send that out in an email. Trustee Alfano also confirmed the dates of August 21st and 22nd.

18. Village Clerk's Report

None

19. Village Trustees' Report

Trustee Kumar:

Just wanted to shout out to a past trustee, David Ciella, who is having health issues and want to send my prayers to get better.

The G.R.E.E.N. Commission did not meet due to a quorum and looking forward to the next one.

Trustee Sabri: Nothing to Report

Trustee Alfano:

It is an honor and privilege to sit her and represent Villa Park.

Thank you to our Police Department and other departments for keeping our children safe and the community. We had an issue at the high school and I wanted to thank them, as a parent and as a teacher.

Prairie Path cleanup is on April 25th and there is a meeting tomorrow where you can learn more about this event.

Villa Fest Subcommittee meets here tomorrow at 7 p.m.

Community Recreation Commission will meet on this Wednesday at 7 p.m.

I'm proud and honored to share with the people on this dais and want to remind them that we do have decorum. We have a Trustee Handbook and think we need to remember that. We have that and we need to treat each other respectfully.

Trustee Konstatos: Nothing to Report

Trustee Cordova: Nothing to Report

Trustee Kozar:

4 hours and 35 minutes after we started – nothing else necessary to say. No report.

20. Village President's Report

Regarding the Willowbrook High School evacuation, the effort to collaborate and work with each other was outstanding. District 88, District 45, Islamic Foundation, Lombard Police Department, and the Villa Park Police Department, as well as Public Works and Parks Department helping with traffic control. The Villa Park Police Department did an outstanding job. Thank you to everyone.

Villa Park Police Department and Willowbrook High School had the Polar Plunge and raised over \$5,000 for Special Olympics Illinois. Thank you to the Police Department. The VFW Fish Fry is this Friday and there are only 2 more left for the annual fish fry. The 4th of July Parade will be celebrating their 250th anniversary this year. Similar to the beam signing at the new Rec Center, there will be a banner for the community to sign before, during and after the parade. It will be preserved and displayed at a Village location. Garden Village Commission has their meeting regarding the new park that was approved by the board. There will be a community park naming event in the future.

The G.R.E.E.N. Commission has two vacancies. Interested? Applications are online.

Thank you to the DuPage Monarch Program and Conservation for their presentation at the last Garden Village Commission meeting.

Spring break is next week. I hope everyone stays safe and have fun.

21. Village Manager's Report

Shout out to Carlos Cruz retired from the Police Department after 20 years.

22. Executive Session

Due to the time, Manager Rivas is willing to allow us to have this conversation at our next meeting, if the Board is in agreement with that.

23. Adjournment

Motion to adjourn made by Trustee Cordova and seconded by Trustee Kumar.

Voice Vote:

Ayes: All

Nays: None

Motion Passed. Adjourn at 11:43 p.m.

Respectfully Submitted,

Rolf Laukant

Village Clerk



MEMORANDUM

TO: Village Board of Trustees

FROM:

DATE: April 13, 2026

SUBJECT: An Ordinance providing for the issue of not to exceed \$9,500,000 General Obligation Refunding Bonds of the Village of Villa Park, DuPage County, Illinois, for the purpose of refunding outstanding obligations of the Village, providing for the levy and collection of a direct annual tax sufficient to pay the principal and interest on said bonds, and authorizing the sale of said bonds to the purchaser thereof.

RECOMMENDED ACTION:

This ordinance essentially refinances the Village's General Obligation Bonds from 2014 to save interest costs.

BACKGROUND:

The Village still has outstanding payments on its General Obligation Bonds, Series 2014, which were authorized by a voter referendum in November 2014. The Village has determined that it can achieve debt service savings by issuing new bonds to refund those 2014 bonds. The new bonds will be in an amount not to exceed \$9.5 million.

DISCUSSION:

EXTRACT OF MINUTES of a public meeting of the President and Board of Trustees of the Village of Villa Park, DuPage County, Illinois, held in the Village Hall Boardroom, 20 S. Ardmore Avenue, Villa Park, Illinois at 7:00 o'clock P.M., on the 13th day of April, 2026.

* * *

The President called the meeting to order and directed the Village Clerk to call the roll.

Upon the roll being called, Kevin Patrick, the President, and the following Trustees answered present at said location: _____

The following Trustees were allowed by a majority of the members of the President and Board of Trustees in accordance with and to the extent allowed by rules adopted by the President and Board of Trustees to attend the meeting by video or audio conference: _____

No Trustee was not permitted to attend the meeting by video or audio conference.

The following Trustees were absent and did not participate in the meeting in any manner or to any extent whatsoever: _____

The President announced that the next item for consideration was an ordinance providing for the issuance of not to exceed \$9,500,000 general obligation bonds to be issued by the Village for the purpose of refunding outstanding obligations of the Village, and that the Board would consider the adoption of an ordinance providing for the issue of said bonds and the levy of a direct annual tax sufficient to pay the principal and interest thereon. The President then explained that the ordinance sets forth the parameters for the issuance of said bonds and sale thereof by designated officials of the Village and summarized the pertinent terms of said parameters, including the

specific parameters governing the manner of sale, length of maturity, rates of interest, purchase price and tax levy for said bonds.

Whereupon Trustee _____ presented, and the Village Clerk read by title an ordinance as follows, a copy of which was provided to each Trustee prior to said meeting and to everyone in attendance at said meeting who requested the same:

ORDINANCE NO. _____

AN ORDINANCE providing for the issue of not to exceed \$9,500,000 General Obligation Refunding Bonds of the Village of Villa Park, DuPage County, Illinois, for the purpose of refunding outstanding obligations of the Village, providing for the levy and collection of a direct annual tax sufficient to pay the principal and interest on said bonds, and authorizing the sale of said bonds to the purchaser thereof.

Adopted by the President and Board of Trustees of the Village of Villa Park, DuPage County, Illinois, on the 13th day of April, 2026.

ORDINANCE NO. _____

AN ORDINANCE providing for the issue of not to exceed \$9,500,000 General Obligation Refunding Bonds of the Village of Villa Park, DuPage County, Illinois, for the purpose of refunding outstanding obligations of the Village, providing for the levy and collection of a direct annual tax sufficient to pay the principal and interest on said bonds, and authorizing the sale of said bonds to the purchaser thereof.

* * *

WHEREAS, the Village of Villa Park, DuPage County, Illinois (the "*Village*"), is a duly organized and existing municipality incorporated and existing under the provisions of the laws of the State of Illinois (the "*State*"), and is now operating under the provisions of the Illinois Municipal Code, as amended (the "*Municipal Code*") and the Local Government Debt Reform Act of the State of Illinois, as amended (the "*Debt Reform Act*"); and

WHEREAS, the Village has heretofore issued and has outstanding its General Obligation Bonds, Series 2014, dated December 29, 2014 (the "*Prior Bonds*"); and

WHEREAS, the President and Board of Trustees of the Village (the "*Board*") hereby finds and determines that it is necessary and desirable and in the best interests of the Village to refund all or a portion of the outstanding Prior Bonds (said portion of the Prior Bonds to be refunded being referred to herein as the "*Refunded Bonds*") to achieve debt service savings for the Village (the "*Refunding*"); and

WHEREAS, the Refunded Bonds shall be fully described in the Bond Notification (as hereinafter defined) and are presently outstanding and unpaid and are binding and subsisting legal obligations of the Village; and

WHEREAS, the Board has determined that in order to refund the Refunded Bonds, it is necessary and in the best interests of the Village to borrow not to exceed \$9,500,000 and issue

bonds of the Village therefor in accordance with the provisions of the Municipal Code and the Debt Reform Act; and

WHEREAS, the Bonds to be issued hereunder shall be payable from a direct annual ad valorem tax levied against all taxable property in the Village, without limitation as to rate or amount; and

WHEREAS, the Property Tax Extension Limitation Law of the State of Illinois, as amended (the "*PTELL*"), imposes certain limitations on the "*aggregate extension*" of certain property taxes levied by the District, but provides that the definition of "*aggregate extension*" applicable to the District contained in Section 18-185 of the Property Tax Code of the State of Illinois, as amended, does not include extensions "made for any taxing district to pay interest or principal on bonds issued to refund or continue to refund bonds issued after October 1, 1991 that were approved by referendum"; and

WHEREAS, the Board hereby finds and determines that the Prior Bonds were authorized by a referendum approved by the voters of the Village on the 4th day of November, 2014; and

WHEREAS, the County Clerk of The County of DuPage, Illinois (the "*County Clerk*"), is therefore authorized to extend and collect said tax so levied for the payment of the bonds to be issued hereunder without limitation as to rate or amount; and

WHEREAS, the outstanding Prior Bonds are subject to redemption prior to maturity at the option of the Village in accordance with the terms of the ordinances pursuant to which such Prior Bonds were issued, and it is necessary and desirable to authorize the call of the Prior Bonds for redemption prior to maturity in connection with the Refunding:

NOW, THEREFORE, Be It Ordained by the President and Board of Trustees of the Village of Villa Park, DuPage County, Illinois, as follows:

Section 1. Incorporation of Preambles. The Board hereby finds that all of the recitals contained in the preambles to this Ordinance are full, true and correct and does incorporate them into this Ordinance by this reference.

Section 2. Authorization; Determination to Issue Bonds. It is hereby found and determined that the Board has been authorized by law to borrow the sum of \$9,500,000 upon the credit of the Village and as evidence of such indebtedness to issue bonds of the Village in said amount, the proceeds of said bonds to be used to finance the Refunding, and that it is necessary and for the best interests of the Village that there be issued at this time not to exceed \$9,500,000 of the bonds so authorized. It is hereby found and determined that such borrowing is necessary for the welfare of the government and affairs of the Village, is for a proper public purpose or purposes and is in the public interest, and is authorized pursuant to the applicable provisions of the Municipal Code and the Debt Reform Act (together, the “Act”), and these findings and determinations, together with those set forth in the preambles to this Ordinance, shall be deemed conclusive.

Section 3. Bond Details. There shall be issued and sold the Bonds in an aggregate principal amount of not to exceed \$9,500,000. The Bonds shall each be designated “*General Obligation Refunding Bond, Series 2026A*”, with such alternative or additional designations necessary to properly identify the Bonds as shall be set forth in the Bond Notification, shall be dated the date of delivery thereof and shall also bear the date of authentication thereof. The Bonds may be issued in one or more series, with a separate Bond Notification to be executed in connection with each series of the Bonds as described in this Ordinance, shall be in fully registered form, shall be in denominations of \$5,000 each or integral multiples thereof (but no single Bond shall represent principal maturing on more than one date), or such other denominations as set forth in the Bond Notification and shall be numbered 1 and upward. The Bonds may be issued such that the interest

thereon is excludible from gross income of the owners thereof ("*Tax-Exempt Bonds*") in accordance with the Internal Revenue Code of 1986, as amended (the "*Code*"), or the Bonds may be issued such that the thereon is includible in gross income of the owners thereof in accordance with the Code ("*Taxable Bonds*"), as set forth in the Bond Notification. The Bonds shall become due and payable serially or be subject to mandatory redemption (subject to prior redemption as hereinafter set forth) on December 15 of the years (not later than 2034), in the amounts (not exceeding \$1,300,000 per year) and bearing interest at the rates per annum (not exceeding 5.00% per annum) as set forth in the Bond Notification.

The Bonds shall bear interest from their date or from the most recent interest payment date to which interest has been paid or duly provided for, until the principal amount of the Bonds is paid, such interest (computed upon the basis of a 360-day year of twelve 30-day months) being payable semi-annually on June 15 and December 15 of each year (or such other dates as set forth in the Bond Notification), commencing on the date set forth in the Bond Notification.

Interest on each Bond shall be paid by check or draft of the bond registrar and paying agent, which shall be the Purchaser (as hereinafter defined), the Treasurer of the Village (the "*Treasurer*") or a bank or trust company authorized to do business in the State of Illinois (as set forth in the Bond Notification) (the "*Bond Registrar*"), payable upon presentation thereof in lawful money of the United States of America, to the person in whose name such Bond is registered at the close of business on the 1st day of the month of any interest payment date (the "*Record Date*"), *provided, however*, that if the interest payment dates are modified in the Bond Notification, the Record Date shall be adjusted in the Bond Notification. The principal of the Bonds shall be payable in lawful money of the United States of America upon presentation thereof at the principal corporate trust office of the Bond Registrar.

Section 4. Execution; Authentication. The Bonds shall be executed on behalf of the Village by the manual or facsimile signature of the President of the Village (the “*President*”) and attested by the manual or facsimile signature of the Village Clerk (the “*Clerk*”), as they shall determine, and the seal of the Village or a facsimile thereof shall be affixed to or printed on each of the Bonds, and in case any officer whose signature shall appear on any Bond shall cease to be such officer before the delivery of such Bond, such signature shall nevertheless be valid and sufficient for all purposes, the same as if such officer had remained in office until delivery.

All Bonds shall have thereon a certificate of authentication substantially in the form hereinafter set forth duly executed by the Bond Registrar, as authenticating agent of the Village for the Bonds and showing the date of authentication. No Bond shall be valid or obligatory for any purpose or be entitled to any security or benefit under this Ordinance unless and until such certificate of authentication shall have been duly executed by the Bond Registrar by manual signature, and such certificate of authentication upon any such Bond shall be conclusive evidence that such Bond has been authenticated and delivered under this Ordinance. The certificate of authentication on any Bond shall be deemed to have been executed by the Bond Registrar if signed by an authorized officer of the Bond Registrar, but it shall not be necessary that the same officer sign the certificate of authentication on all of the Bonds issued hereunder.

Section 5. Registration of Bonds; Persons Treated as Owners. (a) *General.* The Village shall cause books (the “*Bond Register*”) for the registration and for the transfer of the Bonds as provided in this Ordinance to be kept at the principal corporate trust office of the Bond Registrar, which is hereby constituted and appointed the registrar of the Village for the Bonds. The Village is authorized to prepare, and the Bond Registrar shall keep custody of, multiple Bond blanks executed by the Village for use in the transfer and exchange of Bonds.

Upon surrender for transfer of any Bond at the principal corporate trust office of the Bond Registrar, duly endorsed by, or accompanied by a written instrument or instruments of transfer in form satisfactory to the Bond Registrar and duly executed by, the registered owner or his or her attorney duly authorized in writing, the Village shall execute and the Bond Registrar shall authenticate, date and deliver in the name of the transferee or transferees a new fully registered Bond or Bonds of the same maturity of authorized denominations, for a like aggregate principal amount. Any fully registered Bond or Bonds may be exchanged at said office of the Bond Registrar for a like aggregate principal amount of Bond or Bonds of the same maturity of other authorized denominations. The execution by the Village of any fully registered Bond shall constitute full and due authorization of such Bond and the Bond Registrar shall thereby be authorized to authenticate, date and deliver such Bond, *provided, however*, that the principal amount of outstanding Bonds of each maturity authenticated by the Bond Registrar shall not exceed the authorized principal amount of Bonds for such maturity less previous retirements.

The Bond Registrar shall not be required to transfer or exchange any Bond during the period beginning at the close of business on the 1st day of the month of any interest payment date on such Bond and ending on such interest payment date, nor to transfer or exchange any Bond after notice calling such Bond for redemption has been mailed, nor during a period of fifteen (15) days next preceding mailing of a notice of redemption of any Bonds.

The person in whose name any Bond shall be registered shall be deemed and regarded as the absolute owner thereof for all purposes, and payment of the principal of or interest on any Bond shall be made only to or upon the order of the registered owner thereof or his or her legal representative. All such payments shall be valid and effectual to satisfy and discharge the liability upon such Bond to the extent of the sum or sums so paid.

No service charge shall be made for any transfer or exchange of Bonds, but the Village or the Bond Registrar may require payment of a sum sufficient to cover any tax or other governmental charge that may be imposed in connection with any transfer or exchange of Bonds, except in the case of the issuance of a Bond or Bonds for the unredeemed portion of a Bond surrendered for redemption.

(b) *Global Book-Entry System.* The Bonds shall be initially issued in the form of a separate single fully registered Bond for each of the maturities of the Bonds determined as described in Section 3 hereof. Unless otherwise requested by the hereinafter defined Purchaser, upon initial issuance, the ownership of each such Bond shall be registered in the Bond Register in the name of Cede & Co., or any successor thereto (“*Cede*”), as nominee of The Depository Trust Company, New York, New York, and its successors and assigns (“*DTC*”). All of the outstanding Bonds shall be registered in the Bond Register in the name of Cede, as nominee of DTC, except as hereinafter provided. The President, the Clerk, the Village Manager, Finance Director, the Treasurer and the Bond Registrar are each authorized to execute and deliver, on behalf of the Village, such letters to or agreements with DTC as shall be necessary to effectuate such book-entry system (any such letter or agreement being referred to herein as the “*Representation Letter*”), which Representation Letter may provide for the payment of principal of or interest on the Bonds by wire transfer.

With respect to Bonds registered in the Bond Register in the name of Cede, as nominee of DTC, the Village and the Bond Registrar shall have no responsibility or obligation to any broker-dealer, bank or other financial institution for which DTC holds Bonds from time to time as securities depository (each such broker-dealer, bank or other financial institution being referred to herein as a “*DTC Participant*”) or to any person on behalf of whom such a DTC Participant holds an interest in the Bonds. Without limiting the immediately preceding sentence, the Village and

the Bond Registrar shall have no responsibility or obligation with respect to (i) the accuracy of the records of DTC, Cede or any DTC Participant with respect to any ownership interest in the Bonds, (ii) the delivery to any DTC Participant or any other person, other than a registered owner of a Bond as shown in the Bond Register, of any notice with respect to the Bonds, including any notice of redemption, or (iii) the payment to any DTC Participant or any other person, other than a registered owner of a Bond as shown in the Bond Register, of any amount with respect to the principal of or interest on the Bonds. The Village and the Bond Registrar may treat and consider the person in whose name each Bond is registered in the Bond Register as the holder and absolute owner of such Bond for the purpose of payment of principal and interest with respect to such Bond, for the purpose of giving notices of redemption and other matters with respect to such Bond, for the purpose of registering transfers with respect to such Bond, and for all other purposes whatsoever. The Bond Registrar shall pay all principal of and interest on the Bonds only to or upon the order of the respective registered owners of the Bonds, as shown in the Bond Register, or their respective attorneys duly authorized in writing, and all such payments shall be valid and effective to fully satisfy and discharge the Village's obligations with respect to payment of the principal of and interest on the Bonds to the extent of the sum or sums so paid. No person other than a registered owner of a Bond as shown in the Bond Register, shall receive a Bond evidencing the obligation of the Village to make payments of principal and interest with respect to any Bond. Upon delivery by DTC to the Bond Registrar of written notice to the effect that DTC has determined to substitute a new nominee in place of Cede, and subject to the provisions in Section 3 hereof with respect to the payment of interest to the registered owners of Bonds at the close of business on the 1st day of the month of the applicable interest payment date, the name "Cede" in this Ordinance shall refer to such new nominee of DTC.

In the event that (i) the Village determines that DTC is incapable of discharging its responsibilities described herein and in the Representation Letter, (ii) the agreement among the Village, the Bond Registrar and DTC evidenced by the Representation Letter shall be terminated for any reason or (iii) the Village determines that it is in the best interests of the beneficial owners of the Bonds that they be able to obtain certificated Bonds, the Village shall notify DTC and DTC Participants of the availability through DTC of certificated Bonds and the Bonds shall no longer be restricted to being registered in the Bond Register in the name of Cede, as nominee of DTC. At that time, the Village may determine that the Bonds shall be registered in the name of and deposited with such other depository operating a universal book-entry system, as may be acceptable to the Village, or such depository's agent or designee, and if the Village does not select such alternate universal book-entry system, then the Bonds may be registered in whatever name or names registered owners of Bonds transferring or exchanging Bonds shall designate, in accordance with the provisions of Section 4(a) hereof.

Notwithstanding any other provisions of this Ordinance to the contrary, so long as any Bond is registered in the name of Cede, as nominee of DTC, all payments with respect to principal of and interest on such Bond and all notices with respect to such Bond shall be made and given, respectively, in the name provided in the Representation Letter.

Section 6. Redemption. Redemption. (a) Optional Redemption. All or a portion of the Bonds, if any, due on and after the date, if any, specified in the Bond Notification shall be subject to redemption prior to maturity at the option of the Village from any available funds, as a whole or in part, and if in part in integral multiples of \$5,000 in any order of their maturity as determined by the Village (less than all of the Bonds of a single maturity to be selected by the Bond Registrar), on the date specified in the Bond Notification, if any, and on any date thereafter, at the redemption price of par plus accrued interest to the date fixed for redemption.

(b) *Mandatory Redemption.* The Bonds maturing on the date or dates, if any, indicated in the Bond Notification are subject to mandatory redemption, in integral multiples of \$5,000 selected by lot by the Bond Registrar, at a redemption price of par plus accrued interest to the redemption date for the Bonds, on the dates and in the principal amounts, if any, as indicated in the Bond Notification.

The principal amounts of Bonds to be mandatorily redeemed in each year may be reduced through the earlier optional redemption thereof, with any partial optional redemptions of such Bonds credited against future mandatory redemption requirements in such order of the mandatory redemption dates as the Village may determine. In addition, on or prior to the 60th day preceding any mandatory redemption date, the Bond Registrar may, and if directed by the Board shall, purchase Bonds required to be retired on such mandatory redemption date. Any such Bonds so purchased shall be cancelled and the principal amount thereof shall be credited against the mandatory redemption required on such next mandatory redemption date.

(c) *General.* The Bonds shall be redeemed only in the principal amount of \$5,000 and integral multiples thereof. The Village shall, at least forty-five (45) days prior to any optional redemption date (unless a shorter time period shall be satisfactory to the Bond Registrar) notify the Bond Registrar of such redemption date and of the principal amount and maturity or maturities of Bonds to be redeemed. For purposes of any redemption of less than all of the outstanding Bonds of a single maturity, the particular Bonds or portions of Bonds to be redeemed shall be selected by lot by the Bond Registrar from the Bonds of such maturity by such method of lottery as the Bond Registrar shall deem fair and appropriate; *provided* that such lottery shall provide for the selection for redemption of Bonds or portions thereof so that any \$5,000 Bond or \$5,000 portion of a Bond shall be as likely to be called for redemption as any other such \$5,000 Bond or \$5,000 portion. The Bond Registrar shall make such selection upon the earlier of the irrevocable deposit of funds

with an escrow agent sufficient to pay the redemption price of the Bonds to be redeemed or the time of the giving of official notice of redemption.

The Bond Registrar shall promptly notify the Village in writing of the Bonds or portions of Bonds selected for redemption and, in the case of any Bond selected for partial redemption, the principal amount thereof to be redeemed.

Section 7. Redemption Procedure. Unless waived by any holder of Bonds to be redeemed, notice of the call for any such redemption shall be given by the Bond Registrar on behalf of the Village by mailing the redemption notice by first class mail at least thirty (30) days and not more than sixty (60) days prior to the date fixed for redemption to the registered owner of the Bond or Bonds to be redeemed at the address shown on the Bond Register or at such other address as is furnished in writing by such registered owner to the Bond Registrar.

All notices of redemption shall state:

- (1) the redemption date,
- (2) the redemption price,
- (3) if less than all outstanding Bonds are to be redeemed, the identification (and, in the case of partial redemption, the respective principal amounts) of the Bonds to be redeemed,
- (4) that on the redemption date the redemption price will become due and payable upon each such Bond or portion thereof called for redemption, and that interest thereon shall cease to accrue from and after said date,
- (5) the place where such Bonds are to be surrendered for payment of the redemption price, which place of payment shall be the principal corporate trust office of the Bond Registrar, and
- (6) such other information then required by custom, practice or industry standard.

Unless moneys sufficient to pay the redemption price of the Bonds to be redeemed at the option of the Village shall have been received by the Bond Registrar prior to the giving of such notice of redemption, such notice may, at the option of the Village, state that said redemption shall

be conditional upon the receipt of such moneys by the Bond Registrar on or prior to the date fixed for redemption. If such moneys are not received, such notice shall be of no force and effect, the Village shall not redeem such Bonds, and the Bond Registrar shall give notice, in the same manner in which the notice of redemption shall have been given, that such moneys were not so received and that such Bonds will not be redeemed. Otherwise, prior to any redemption date, the Village shall deposit with the Bond Registrar an amount of money sufficient to pay the redemption price of all the Bonds or portions of Bonds which are to be redeemed on that date.

Subject to the provisions for a conditional redemption described above, notice of redemption having been given as aforesaid, the Bonds or portions of Bonds so to be redeemed shall, on the redemption date, become due and payable at the redemption price therein specified, and from and after such date (unless the Village shall default in the payment of the redemption price) such Bonds or portions of Bonds shall cease to bear interest. Upon surrender of such Bonds for redemption in accordance with said notice, such Bonds shall be paid by the Bond Registrar at the redemption price. Installments of interest due on or prior to the redemption date shall be payable as herein provided for payment of interest. Upon surrender for any partial redemption of any Bond, there shall be prepared for the registered holder a new Bond or Bonds of the same maturity in the amount of the unpaid principal.

If any Bond or portion of Bond called for redemption shall not be so paid upon surrender thereof for redemption, the principal shall, until paid, bear interest from the redemption date at the rate borne by the Bond or portion of Bond so called for redemption. All Bonds which have been redeemed shall be cancelled and destroyed by the Bond Registrar and shall not be reissued.

Section 8. Form of Bond. The Bonds shall be in substantially the following form; *provided, however,* that if the text of the Bond is to be printed in its entirety on the front side of the Bond, then paragraph [2] and the legend, “See Reverse Side for Additional Provisions”, shall

be omitted and paragraph [6] and those thereafter, as may be appropriate, shall be inserted immediately after paragraph [1]:

(Form of Bond - Front Side)

REGISTERED
NO. _____

REGISTERED
\$ _____

UNITED STATES OF AMERICA

STATE OF ILLINOIS

COUNTY OF DUPAGE

VILLAGE OF VILLA PARK

**GENERAL OBLIGATION REFUNDING BOND,
SERIES 2026A**

See Reverse Side for
Additional Provisions

Interest Maturity Dated
Rate: ____% Date: December 15, 20__ Date: _____, 2026 CUSIP: _____

Registered Owner:

Principal Amount:

[1] KNOW ALL PERSONS BY THESE PRESENTS, that the Village of Villa Park, DuPage County, Illinois (the “*Village*”), hereby acknowledges itself to owe and for value received promises to pay to the Registered Owner identified above, or registered assigns as hereinafter provided, on the Maturity Date identified above, the Principal Amount identified above and to pay interest (computed on the basis of a 360-day year of twelve 30-day months) on such Principal Amount from the date of the Bond or from the most recent interest payment date to which interest has been paid at the Interest Rate per annum set forth above on June 15 and December 15 of each year, commencing _____ 15, 20__, until said Principal Amount is paid. The principal of this Bond is payable in lawful money of the United States of America at the principal corporate trust office of _____, as bond registrar and paying agent (the “*Bond Registrar*”). Payment of the installments of interest shall be made to the Registered Owner hereof as shown on

the registration books of the Village maintained by the Bond Registrar at the close of business on the 1st day of the month of any interest payment date and shall be paid by check or draft of the Bond Registrar, payable upon presentation in lawful money of the United States of America, mailed to the address of such Registered Owner as it appears on such registration books or at such other address furnished in writing by such Registered Owner to the Bond Registrar. For the prompt payment of this Bond both principal and interest at maturity, the full faith, credit and resources of the Village are hereby irrevocably pledged.

[2] Reference is hereby made to the further provisions of this Bond set forth on the reverse hereof and such further provisions shall for all purposes have the same effect as if set forth at this place.

[3] It is hereby certified and recited that all conditions, acts and things required by law to exist or to be done precedent to and in the issuance of this bond did exist, have happened, been done and performed in regular and due form and time as required by law; that the indebtedness of the Village, including the issue of bonds of which this is one, does not exceed any limitation imposed by law; and that provision has been made for the collection of a direct annual tax in addition to all other taxes, on all of the taxable property in the Village sufficient to pay the interest hereon as the same falls due and also to pay and discharge the principal hereof at maturity.

[4] This Bond shall not be valid or become obligatory for any purpose until the certificate of authentication hereon shall have been signed by the Bond Registrar.

[5] IN WITNESS WHEREOF, said Village of Villa Park, DuPage County, Illinois, by its President and Board of Trustees, has caused its corporate seal to be imprinted by facsimile hereon or hereunto affixed, and this bond to be signed by the manual or duly authorized facsimile signature of the President of the Village and attested by the manual or duly authorized facsimile signature of the Clerk of the Village, all as of the Dated Date identified above.

SPECIMEN
President

Attest:

SPECIMEN
Village Clerk

Date of Authentication: _____, 20__

CERTIFICATE
OF
AUTHENTICATION

Bond Registrar and Paying Agent:

This Bond is one of the Bonds described in the within mentioned Ordinance and is one of the General Obligation Refunding Bonds, Series 2026A, of the Village of Villa Park, DuPage County, Illinois.

_____,
as Bond Registrar

By _____
SPECIMEN
Authorized Officer

[Form of Bond - Reverse Side]

VILLAGE OF VILLA PARK

DUPAGE COUNTY, ILLINOIS

[TAXABLE] GENERAL OBLIGATION REFUNDING BOND, SERIES 2026__

[6] This Bond is one of a series of bonds (the “*Bonds*”) issued by the Village for the purpose of refunding certain outstanding obligations of the Village, all as described and defined in the ordinance of the Village, passed by the President and Board of Trustees of the Village on the 13th day of April, 2026, authorizing the Bonds (as supplemented by a notification of sale, the “*Ordinance*”), pursuant to and in all respects in compliance with the applicable provisions of the Illinois Municipal Code, as amended, and as supplemented by the Local Government Debt Reform Act, as amended (together, such Illinois Municipal Code and Local Government Debt Reform Act being the “*Act*”).

[7] [Bonds of the issue of which this Bond is one maturing on and after December 15, 20__, are subject to redemption prior to maturity at the option of the Village as a whole, or in part in integral multiples of \$5,000 in any order of their maturity as determined by the Village (less than all the Bonds of a single maturity to be selected by lot by the Bond Registrar), on December 15, 20__, and on any date thereafter, at the redemption price of par plus accrued interest to the redemption date.]

[8] [Mandatory redemption provisions to be inserted as necessary]

[9] Notice of any such redemption shall be sent by first class mail not less than thirty (30) days nor more than sixty (60) days prior to the date fixed for redemption to the registered owner of each Bond to be redeemed at the address shown on the registration books of the Village maintained by the Bond Registrar or at such other address as is furnished in writing by such registered owner to the Bond Registrar. When so called for redemption, this Bond will cease to

bear interest on the specified redemption date, provided funds for redemption are on deposit at the place of payment at that time, and shall not be deemed to be outstanding.

[10] This Bond is transferable by the registered holder hereof in person or by his or her attorney duly authorized in writing at the principal corporate trust office of the Bond Registrar in _____, but only in the manner, subject to the limitations and upon payment of the charges provided in the Bond Ordinance, and upon surrender and cancellation of this Bond. Upon such transfer a new Bond or Bonds of authorized denominations of the same maturity and for the same aggregate principal amount will be issued to the transferee in exchange therefor.

[11] The Bonds are issued in fully registered form in the denomination of \$5,000 each or integral multiples thereof. This Bond may be exchanged at the principal corporate trust office of the Bond Registrar for a like aggregate principal amount of Bonds of the same maturity of other authorized denominations, upon the terms set forth in the Ordinance. The Bond Registrar shall not be required to transfer or exchange any Bond during the period beginning at the close of business on the 1st day of the month of any interest payment date on such Bond and ending at the opening of business on such interest payment date, nor to transfer or exchange any Bond after notice calling such Bond for redemption has been mailed, nor during a period of fifteen (15) days next preceding mailing of a notice of redemption of any Bonds.

[12] The Village and the Bond Registrar may deem and treat the registered holder hereof as the absolute owner hereof for the purpose of receiving payment of or on account of principal hereof and interest due hereon and for all other purposes and neither the Village nor the Bond Registrar shall be affected by any notice to the contrary.

(ASSIGNMENT)

FOR VALUE RECEIVED, the undersigned sells, assigns, and transfers unto _____

(Name and Address of Assignee)

the within Bond and does hereby irrevocably constitute and appoint _____

attorney to transfer the said Bond on the books kept for registration thereof with full power of substitution in the premises.

Dated: _____

Signature guaranteed: _____

NOTICE: The signature to this assignment must correspond with the name of the registered owner as it appears upon the face of the within Bond in every particular, without alteration or enlargement or any change whatever.

Section 9. Sale of Bonds. The (i) President and (ii) the Village Manager or Finance Director of the Village (collectively, the “*Designated Representatives*”), are hereby authorized to proceed not later than 13th day of April, 2026, without any further authorization or direction from the Board, to sell the Bonds upon the terms as prescribed in this Ordinance. The Bonds hereby authorized shall be executed as in this Ordinance provided as soon after the delivery of the Bond Notification as may be, and thereupon be deposited with the Treasurer, and, after authentication thereof by the Bond Registrar, be by the Treasurer delivered to the purchaser or purchasers thereof (the “*Purchaser*”) upon receipt of the purchase price therefor, the same being not less than 99.00% of the principal amount of the Bonds (exclusive of original issue discount), plus accrued interest to the date of delivery, if any.

The Purchaser of the Bonds shall be: (a) pursuant to a competitive sale conducted by Speer Financial, Inc., Chicago, Illinois (“*Speer*”), the best bidder for the Bonds; (b) in a negotiated

underwriting, a bank or financial institution listed in the Dealers & Underwriters or Municipal Derivatives sections of the most recent edition of The Bond Buyer's Municipal Marketplace; or (c) in a private placement, (i) a bank or financial institution authorized to do business in the State of Illinois, (ii) a governmental unit as defined in the Debt Reform Act, or (iii) an "accredited investor" as defined in Rule 501 of Regulation D as promulgated under the Securities Act of 1933, as amended; provided, however that the Purchaser as set forth in either (b) or (c) shall be selected only upon receipt by the Village of the written recommendation of Speer that the sale of the Bonds on a negotiated or private placement basis to the Purchaser is in the best interest of the Village because of (i) the pricing of the Bonds by the Purchaser, (ii) then current market conditions or (iii) the timing of the sale of the Bonds; and further provided that Purchaser set forth in (c) may be selected through the utilization of a placement agent selected by the Designated Representatives after consultation with Speer if the use of such placement agent is determined by the Designated Representatives to be in the best interest of the Village.

Prior to the sale of the Bonds, the President, the Clerk, the Village Manager, Finance Director, the Treasurer or any other official of the Village is hereby authorized to approve and execute a commitment for the purchase of a Municipal Bond Insurance Policy (as hereinafter defined), to further secure the Bonds, as long as the present value of the fee to be paid for the Municipal Bond Insurance Policy (using as a discount rate the expected yield on the Bonds treating the fee paid as interest on the Bonds) is less than the present value of the interest reasonably expected to be saved on the Bonds over the term of the Bonds as a result of the Municipal Bond Insurance Policy.

Upon the sale of the Bonds, the Designated Representatives shall prepare a Notification of Sale, which shall include the pertinent details of sale as provided herein (the "*Bond Notification*"). In the Bond Notification, the Designated Representatives shall find and determine that the Bonds

have been sold at such price and bear interest at such rates that either the true interest cost (yield) or the net interest rate received upon the sale of such series of the Bonds does not exceed the maximum rate otherwise authorized by applicable law. The Bond Notification shall be entered into the records of the Village and made available to the Board at the next regular meeting thereof; but such action shall be for information purposes only, and the Board shall have no right or authority at such time to approve or reject such sale as evidenced in the Bond Notification.

Upon the sale of the Bonds as evidenced by the execution and delivery of the Bond Notification by the Designated Representatives, the President, the Clerk, the Village Manager, Finance Director, the Treasurer or any other officer of the Village (the “*Authorized Officials*”), as shall be appropriate, shall be and are hereby authorized and directed to approve or execute, or both, such documents of sale of such series of the Bonds as may be necessary, including, without limitation, the contract for the sale of the Bonds between the Village and the Purchaser (which may be evidenced by an executed term sheet, commitment letter or bid form) (the “*Purchase Contract*”). Prior to the execution and delivery of the Purchase Contract, the Designated Representatives shall find and determine that no person holding any office of the Village, either by election or appointment, is in any manner financially interested either directly in his or her own name or indirectly in the name of any other person, association, trust or corporation, in the Purchase Contract. Any of the Authorized Officials are also authorized to execute a continuing covenants agreement or other document required by a Purchaser in connection with the sale of the Bonds and to determine the terms thereof, *provided, however*, that none of the terms thereof shall conflict with the terms of this Ordinance. If determined to be necessary to effectuate the issuance of the Bonds and in the best interests of the Village by the Designated Representatives, the Village is authorized to pay to the Purchaser a commitment fee or other fee in connection with the issuance

of the Bonds, said determination of the Designated Representatives, and the amount of any such fee, to be set forth in the Bond Notification.

The Bonds before being issued shall be registered, numbered and countersigned by the Treasurer, such registration being made in a book provided for that purpose, in which shall be entered the record of the ordinance authorizing the Board to borrow said money and a description of the Bonds issued, including the number, date, to whom issued, amount, rate of interest and when due.

The use by the Purchaser of any Preliminary Official Statement and any final Official Statement relating to the Bonds (the "*Official Statement*") and by the Village of any term sheet with respect to the Bonds is hereby ratified, approved and authorized; the execution and delivery of the Official Statement and any term sheet is hereby authorized; and the officers of the Village are hereby authorized to take any action as may be required on the part of the Village to consummate the transactions contemplated by the Purchase Contract, this Ordinance, said Preliminary Official Statement, the Official Statement, any term sheet and the Bonds.

Section 10. Tax Levy. For the purpose of providing the funds required to pay the interest on the Bonds as it falls due, and also to pay and discharge the principal thereof at maturity, there be and there shall be levied upon all the taxable property within the Village a direct annual tax for each of the years while the Bonds or any of them are outstanding in amounts sufficient for that purpose, and that there be and there is levied upon all of the said taxable property in the Village in addition to all other taxes the following direct annual tax, to-wit (the "*Pledged Taxes*"):

FOR THE YEAR

A TAX SUFFICIENT TO PRODUCE THE SUM OF:

2026	\$1,600,000.00	for interest and principal up to and including December 1, 2027
2027	\$1,600,000.00	for interest and principal
2028	\$1,600,000.00	for interest and principal
2029	\$1,600,000.00	for interest and principal
2030	\$1,600,000.00	for interest and principal
2031	\$1,600,000.00	for interest and principal
2032	\$1,600,000.00	for interest and principal
2033	\$1,600,000.00	for interest and principal

The Pledged Taxes and other moneys (excepting proceeds of the Bonds) on deposit (collectively, the “*Bond Moneys*”) in the Bond Fund (as hereinafter defined) shall be applied to pay interest when due and principal when due at maturity.

To the extent that the taxes levied above exceed the amount necessary to pay debt service on the Bonds as set forth in the Bond Notification, the President, Clerk and Treasurer are hereby authorized to direct the abatement of such taxes to the extent of the excess of such levy in each year over the amount necessary to pay debt service on the Bonds in the following bond year. Proper notice of such abatement shall be filed with the County Clerk in a timely manner to effect such abatement.

Interest or principal coming due at any time when there are insufficient funds on hand from the Pledged Taxes to pay the same shall be paid promptly when due from current funds on hand in advance of the collection of the Pledged Taxes; and when the Pledged Taxes shall have been collected, reimbursement shall be made to said funds in the amount so advanced. The Village covenants and agrees with the purchasers and registered owners of the Bonds that so long as any of the Bonds remain outstanding, the Village will take no action or fail to take any action which in any way would adversely affect the ability of the Village to levy and collect the foregoing tax levy. The Village and its officers will comply with all present and future applicable laws in order to

assure that the Pledged Taxes may be levied, extended and collected as provided herein and deposited into the Bond Fund.

Whenever other funds from any lawful source are made available for the purpose of paying any principal of or interest on the Bonds so as to enable the abatement of the Pledged Taxes, the Board shall, by proper proceedings, direct the deposit of such funds into the Bond Fund and further shall direct the abatement of the taxes by the amount so deposited. A certified copy or other notification of any such proceedings abating taxes may then be filed with the County Clerk in a timely manner to effect such abatement.

Section 11. Filing of Ordinance. Forthwith as soon as this Ordinance becomes effective, the Clerk is hereby directed to file a copy of said Ordinance with the County Clerk, and the County Clerk shall in and for each of the years 2026 to 2033 ascertain the rate necessary to produce the tax herein levied; and the County Clerk shall extend the same for collection on the tax books in connection with other taxes levied in said years in and by the Village for general corporate purposes of the Village; and, subject to abatement as stated hereinabove, in said years such annual tax shall be levied and collected by and for and on behalf of the Village in like manner as taxes for general corporate purposes for said years are levied and collected, and in addition to and in excess of all other taxes, and when collected, the taxes hereby levied shall be placed to the credit of a special fund to be designated “Refunding Bond and Interest Fund of 2026A” (the “*Bond Fund*”), which taxes are hereby irrevocably pledged to and shall be used only for the purpose of paying the principal of and interest on the Bonds.

Section 12. Creation of Funds and Appropriations

A. Accrued interest and premium, if any, received upon delivery of the Bonds and a portion of the proceeds of the Bonds in the amount set forth in the Bond Notification (said amount not to exceed the interest accruing on the Bonds during the two-year period following the date of

issuance of the Bonds) shall be deposited into the Bond Fund and be applied to pay first interest coming due on the Bonds.

B. The Pledged Taxes shall either be deposited into the Bond Fund and used solely and only for paying the principal of and interest on the Bonds or be used to reimburse a fund or account from which advances to the Bond Fund may have been made to pay principal of or interest on the Bonds prior to receipt of Pledged Taxes. Interest income or investment profit earned in the Bond Fund shall be retained in the Bond Fund for payment of the principal of or interest on the Bonds on the interest payment date next after such interest or profit is received or, to the extent lawful and as determined by the Board, transferred to such other fund as may be determined. The Village hereby pledges, as equal and ratable security for the Bonds, all present and future proceeds of the Pledged Taxes for the sole benefit of the registered owners of the Bonds, subject to the reserved right of the Board to transfer certain interest income or investment profit earned in the Bond Fund to other funds of the Village, as described in the preceding sentence.

C. Simultaneously with the delivery of the Bonds, the balance of the principal proceeds of the Bonds, together with any premium received from the sale of the Bonds and such additional amounts as may be necessary from the general funds of the Village, are hereby appropriated to pay costs of issuance of the Bonds and for the purpose of refunding the Refunded Bonds, and that portion thereof not needed to pay such costs of issuance is hereby ordered deposited the paying agent for the Prior Bonds (the "*Prior Paying Agent*") or (ii) in escrow pursuant to an Escrow Agreement (the "*Escrow Agreement*") to be entered into between the Village and an escrow agent (the same being a bank or trust company authorized to do business in the State of Illinois as set forth in the Bond Notification, the "*Escrow Agent*"), the Escrow Agreement to be executed by one or more Authorized Officers, in such form as the Authorized Officer executing the Escrow Agreement shall determine, such execution to constitute evidence of

the approval of form of the Escrow Agreement, for the purpose of paying the principal of and interest on the Refunded Bonds. Amounts in the escrow may be used to purchase direct obligations of or obligations guaranteed by the full faith and credit of the United States of America (the “*Government Securities*”) to provide for the payment of the principal of and interest on the Refunded Bonds. The Escrow Agent and the Purchaser are each hereby authorized to act as agent for the Village in the purchase of the Government Securities.

At the time of the issuance of the Bonds, the costs of issuance of the Bonds may be paid by the Purchaser or the Bond Registrar on behalf of the Village from the proceeds of the Bonds.

Section 13. Call of Refunded Bonds for Redemption. In accordance with the redemption provisions of the ordinances authorizing the issuance of the Prior Bonds, the Village, by the Board, does hereby make provision for the payment of and does hereby call (subject only to the delivery of the Bonds) the Refunded Bonds on the date set forth in the Bond Notification. The Prior Paying Agent is hereby authorized and directed to give timely notice of the call for redemption of such Refunded Bonds. The form and time of the giving of such notice regarding the redemption of such Refunded Bonds shall be as specified in the respective ordinance authorizing the issuance of a series of the Prior Bonds

Section 14. Non-Arbitrage and Tax-Exemption. The Village hereby covenants that it will not take any action, omit to take any action or permit the taking or omission of any action within its control (including, without limitation, making or permitting any use of the proceeds of the Tax-Exempt Bonds) if taking, permitting or omitting to take such action would cause any of the Tax-Exempt Bonds to be an arbitrage bond or a private activity bond within the meaning of the Code, or would otherwise cause the interest on the Tax-Exempt Bonds to be included in the gross income of the recipients thereof for federal income tax purposes. The Village acknowledges that, in the event of an examination by the Internal Revenue Service (the “*IRS*”) of the exemption

from Federal income taxation for interest paid on the Tax-Exempt Bonds, under present rules, the Village may be treated as a “taxpayer” in such examination and agrees that it will respond in a commercially reasonable manner to any inquiries from the IRS in connection with such an examination.

The Village also agrees and covenants with the purchasers and holders of the Tax-Exempt Bonds from time to time outstanding that, to the extent possible under Illinois law, it will comply with whatever federal tax law is adopted in the future which applies to the Tax-Exempt Bonds and affects the tax-exempt status of the Tax-Exempt Bonds.

The Board hereby authorizes the officials of the Village responsible for issuing the Tax-Exempt Bonds, the same being the President, Clerk and Village Treasurer, to make such further covenants and certifications regarding the specific use of the proceeds of the Tax-Exempt Bonds as approved by the Board and as may be necessary to assure that the use thereof will not cause the Tax-Exempt Bonds to be arbitrage bonds and to assure that the interest on the Tax-Exempt Bonds will be exempt from federal income taxation. In connection therewith, the Village and the Board further agrees: (a) through their officers, to make such further specific covenants, representations as shall be truthful, and assurances as may be necessary or advisable; (b) to consult with counsel approving the Tax-Exempt Bonds and to comply with such advice as may be given; (c) to pay to the United States, as necessary, such sums of money representing required rebates of excess arbitrage profits relating to the Tax-Exempt Bonds; (d) to file such forms, statements, and supporting documents as may be required and in a timely manner; and (e) if deemed necessary or advisable by their officers, to employ and pay fiscal agents, financial advisors, attorneys, and other persons to assist the Village in such compliance.

Section 15. Designation of Issue. If so set forth in the Bond Notification, the Village may designate any of the Tax-Exempt Bonds, to the extent permissible by law, as a “qualified tax-exempt obligation” for the purposes and within the meaning of Section 265(b)(3) of the Code.

Section 16. List of Bondholders. The Bond Registrar shall maintain a list of the names and addresses of the holders of all Bonds and upon any transfer shall add the name and address of the new Bondholder and eliminate the name and address of the transferor Bondholder.

Section 17. Duties of Bond Registrar. If requested by the Bond Registrar, any Authorized Officer is authorized to execute the Bond Registrar’s standard form of agreement between the Village and the Bond Registrar with respect to the obligations and duties of the Bond Registrar hereunder which may include the following:

(a) to act as bond registrar, authenticating agent, paying agent and transfer agent as provided herein;

(b) to maintain a list of Bondholders as set forth herein and to furnish such list to the Village upon request, but otherwise to keep such list confidential;

(c) to give notice of redemption of Bonds as provided herein;

(d) to cancel and/or destroy Bonds which have been paid at maturity or upon earlier redemption or submitted for exchange or transfer;

(e) to furnish the Village at least annually a certificate with respect to Bonds cancelled and/or destroyed; and

(f) to furnish the Village at least annually an audit confirmation of Bonds paid, Bonds outstanding and payments made with respect to interest on the Bonds.

Section 18. Continuing Disclosure Undertaking. The President and the Finance Director are hereby authorized, empowered and directed to execute and deliver a Continuing Disclosure Undertaking under Section (b)(5) of Rule 15c2-12 adopted by the Securities and Exchange Commission pursuant to the Securities Exchange Act of 1934, as amended (the “*Continuing Disclosure Undertaking*”). When the Continuing Disclosure Undertaking is executed and

delivered on behalf of the Village as herein provided, the Continuing Disclosure Undertaking will be binding on the Village and the officers, employees and agents of the Village, and the officers, employees and agents of the Village are hereby authorized, empowered and directed to do all such acts and things and to execute all such documents as may be necessary to carry out and comply with the provisions of the Continuing Disclosure Undertaking as executed. Notwithstanding any other provision of this Ordinance, the sole remedies for failure to comply with the Continuing Disclosure Undertaking shall be the ability of the beneficial owner of any Bond to seek mandamus or specific performance by court order, to cause the Village to comply with its obligations under the Continuing Disclosure Undertaking.

Section 19. Municipal Bond Insurance. In the event the payment of principal and interest on the Bonds is insured pursuant to a municipal bond insurance policy (the “*Municipal Bond Insurance Policy*”) issued by a bond insurer (the “*Bond Insurer*”), and as long as such Municipal Bond Insurance Policy shall be in full force and effect, the Village and the Bond Registrar agree to comply with such usual and reasonable provisions regarding presentment and payment of the Bonds, subrogation of the rights of the Bondholders to the Bond Insurer upon payment of the Bonds by the Bond Insurer, amendment hereof, or other terms, as approved by the Designated Representatives on advice of counsel, his or her approval to constitute full and complete acceptance by the Village of such terms and provisions under authority of this Section.

Section 20. Record-Keeping Policy and Post-Issuance Compliance Matters. On October 27, 2025, the Corporate Authorities adopted a record-keeping policy (the “*Policy*”) to maintain sufficient records to demonstrate compliance with its covenants and expectations to ensure the appropriate federal tax status for the Bonds and other debt obligations of the Village, the interest on which is excludable from “gross income” for federal income tax purposes or which enable the Village or the holder to receive federal tax benefits, including, but not limited to,

qualified tax credit bonds and other specified tax credit bonds (including the Bonds). The Corporate Authorities and the Village hereby reaffirm the Policy.

Section 21. Severability. If any section, paragraph or provision of this Ordinance shall be held to be invalid or unenforceable for any reason, the invalidity or unenforceability of such section, paragraph or provision shall not affect any of the remaining provisions of this Ordinance.

Section 22. Publication of Ordinance. A full, true and complete copy of this Ordinance shall be published within ten days after passage in pamphlet form by authority of the Board.

Section 23. Superseder and Effective Date. All ordinances, resolutions and orders, or parts thereof, in conflict herewith, are to the extent of such conflict hereby superseded, including any provisions of the Code of Ordinances of the Village; and this Ordinance shall be in full force and effect immediately upon its passage, approval and publication.

ADOPTED: April 13, 2026.

AYES: _____

NAYS: _____

ABSENT: _____

Approved: April 13, 2026.

President,
Village of Villa Park,
DuPage County, Illinois

Attest:

Village Clerk,
Village of Villa Park,
DuPage County, Illinois

Trustee _____ moved and Trustee _____ seconded the motion that said ordinance as presented and read by title be adopted.

After a full discussion thereof, the President directed that the roll be called for a vote upon the motion to adopt said ordinance.

Upon the roll being called, the following Trustees voted AYE: _____

The following Trustees voted NAY: _____

Whereupon the President declared the motion carried and said ordinance adopted and directed the Village Clerk to record the same in full in the records of the President and Board of Trustees of the Village of Villa Park, DuPage County, Illinois.

Other business not pertinent to the adoption of said ordinance was duly transacted at said meeting.

Upon motion duly made and seconded, the meeting adjourned.

Village Clerk

STATE OF ILLINOIS)
) SS
COUNTY OF DUPAGE)

CERTIFICATION OF MINUTES AND ORDINANCE

I, the undersigned, do hereby certify that I am the duly qualified and acting Village Clerk of the Village of Villa Park, DuPage County, Illinois (the “*Village*”), and as such official I am the keeper of the official journal of proceedings, books, records, minutes and files of the Village and of the President and Board of Trustees thereof (the “*Board*”).

I do further certify that the foregoing is a full, true and complete transcript of that portion of the minutes of the meeting of the Board held on the 13th day of April, 2026, insofar as the same relates to the adoption of an Ordinance No. ____ entitled:

AN ORDINANCE providing for the issue of not to exceed \$9,500,000 General Obligation Refunding Bonds of the Village of Villa Park, DuPage County, Illinois, for the purpose of refunding outstanding obligations of the Village, providing for the levy and collection of a direct annual tax sufficient to pay the principal and interest on said bonds, and authorizing the sale of said bonds to the purchaser thereof.

(the “*Ordinance*”) a true, correct and complete copy of which said ordinance as adopted at said meeting appears in the foregoing transcript of the minutes of said meeting (the “*Meeting*”).

I do further certify that the deliberations of the Board on the adoption of the Ordinance were taken openly; that the vote on the adoption of the Ordinance was taken openly; that the Meeting was held at a specified time and place convenient to the public; that notice of the Meeting was duly given to all of the news media requesting such notice; that an agenda for each Meeting was posted at the location where the Meeting was held and at the principal office of the Board at least 72 hours in advance of the holding of the Meeting, that at least one copy of each agenda was continuously available for public review during the entirety of such period, that a true, correct and complete copy of the agenda for the Meeting as so posted is attached hereto as *Exhibit A*, that the Meeting was called and held in strict compliance with the provisions of the Open Meetings Act of the State of Illinois, as amended, the Illinois Municipal Code, as amended, and the Code of Ordinances of the Village, and that the Board has complied with all of the provisions of said Act and said Codes and with all of the procedural rules of the Board in the adoption of said ordinance.

IN WITNESS WHEREOF, I hereunto affix my official signature and the seal of the Village,
this 13th day of April, 2026.

Village Clerk

(SEAL)

EXHIBIT A

AGENDA

STATE OF ILLINOIS)
) SS
COUNTY OF DUPAGE)

FILING CERTIFICATE

I, the undersigned, do hereby certify that I am the duly qualified and acting County Clerk of The County of DuPage, Illinois and as such official I do further certify that on the ____ day of _____, 2026, there was filed in my office a duly certified copy of Ordinance No. _____ entitled:

AN ORDINANCE providing for the issue of not to exceed \$9,500,000 General Obligation Refunding Bonds of the Village of Villa Park, DuPage County, Illinois, for the purpose of refunding outstanding obligations of the Village, providing for the levy and collection of a direct annual tax sufficient to pay the principal and interest on said bonds, and authorizing the sale of said bonds to the purchaser thereof.

duly adopted by the President and Board of Trustees of the Village of Villa Park, DuPage County, Illinois, on the 13th day of April, 2026, that the same has been deposited in the official files and records of my office.

IN WITNESS WHEREOF, I hereunto affix my official signature and the seal of The County of DuPage, Illinois, this ____ day of _____, 2026.

County Clerk of The County of DuPage, Illinois

(SEAL)

STATE OF ILLINOIS)
) SS
COUNTY OF DUPAGE)

CERTIFICATE OF PUBLICATION IN PAMPHLET FORM

I, the undersigned, do hereby certify that I am the duly qualified and acting Village Clerk of the Village of Villa Park, DuPage County, Illinois (the “*Village*”), and as such official I am the keeper of the official journal of proceedings, books, records, minutes, and files of the Village and of the President and Board of Trustees (the “*Board*”) thereof.

I do further certify that on the 13th day of April, 2026, there was published in pamphlet form, by authority of the Board, a true, correct and complete copy of Ordinance Number _____ of the Village entitled:

AN ORDINANCE providing for the issue of not to exceed \$9,500,000 General Obligation Refunding Bonds of the Village of Villa Park, DuPage County, Illinois, for the purpose of refunding outstanding obligations of the Village, providing for the levy and collection of a direct annual tax sufficient to pay the principal and interest on said bonds, and authorizing the sale of said bonds to the purchaser thereof.

duly adopted by the Board on the 13th day of April, 2026, and that said ordinance as so published was on said date readily available for public inspection and distribution, in sufficient number to meet the needs of the general public, at my office as Village Clerk located in the Village.

IN WITNESS WHEREOF I have affixed hereto my official signature and the seal of the Village
this 13th day of April, 2026.

Village Clerk

[SEAL]



MEMORANDUM

TO: Village Board of Trustees

FROM:

DATE: April 13, 2026

SUBJECT: Resolution of the Village of Villa Park, DuPage County, Illinois Amending Its Travel Expense Reimbursement Regulations

RECOMMENDED ACTION:

This resolution would adopt minor changes to the Village's Travel Policy regarding approvals and documentation for types of travel.

BACKGROUND:

The Village Board adopted a Travel Policy in 2017 to comply with the Local Government Travel Expense Control Act. That policy included multiple levels of paperwork and approvals for any type of travel-related expense. The proposed changes would simplify the process.

DISCUSSION:

Per statute, forms are only required for expenses that go beyond the approved reimbursement amounts in the travel policy. For Villa Park's policy, that would be limited to very expensive and unbudgeted travel. In those limited cases, the travel form would need to be completed and signed by multiple supervisors. The current policy requires that step for all travel. The proposed revision would meet in the middle: small, in-state travel expenses would not require multiple approvals or detailed form, but anything out-of-state or involving private travel or lodging would. This change will improve administrative function.

RESOLUTION NO. _____

**A RESOLUTION OF THE VILLAGE OF VILLA PARK, DUPAGE COUNTY,
ILLINOIS, AMENDING ITS TRAVEL EXPENSE REIMBURSEMENT
REGULATIONS**

WHEREAS, the Village of Villa Park, DuPage County, Illinois (the "*Village*") is a duly organized and validly existing non-home-rule municipality created in accordance with the Constitution of the State of Illinois of 1970 and the laws of the State; and

WHEREAS, the Village is empowered to create policies and procedures to provide for effective government within the Village; and

WHEREAS, the Village President and Village Trustees (the "*Corporate Authorities*") of the Village previously adopted the Village of Villa Park Travel Policy on January 23, 2017 and later amended (the "*Travel Policy*"); and

WHEREAS, the Corporate Authorities have determined that it is advisable, necessary and in the best interest of the Village to amend the Travel Policy as provided herein.

NOW, THEREFORE, BE IT RESOLVED, by the President and Board of Trustees of the Village of Villa Park, DuPage County, Illinois, as follows:

Section 1: The facts and statements contained in the preamble clauses to this Resolution are found to be true and correct and are hereby adopted as part of this Resolution.

Section 2: The Village of Villa Park Travel Policy is hereby amended and approved as attached hereto as Exhibit A, with the stricken language deleted and the underlined language inserted.

Section 3: The Human Resources Manager of the Village is hereby directed to distribute the amended Travel Policy to all employees of the Village within two days of this Resolution's adoption.

Section 4: This Resolution and the Travel Policy shall be in full force and effect upon the Resolution's passage and approval as provided by law.

[Continued on Next Page]

Resolution No. _____

PASSED this ____ day of _____, 2026.

AYES: _____

NAYS: _____

ABSENT: _____

ABSTAINING: _____

Approved this __ day of _____, 2026.

Kevin Patrick, Village President

Attest:

Rolf Laukant, Village Clerk

Resolution No. _____

Exhibit A

Employee Handbook

(see attached)

VILLAGE OF VILLA PARK TRAVEL POLICY
ADOPTED AND EFFECTIVE ~~SEPTEMBER 25, 2017~~ April 13, 2026

TRAVEL FOR VILLAGE BUSINESS, TRAININGS, OR CONFERENCES

“Travel” means any expenditure directly incident to official travel by employees and officers of the Village involving reimbursement to travelers or direct payment to private agencies providing transportation or related services.

Travel is allowed for trainings, conferences, Village-related association meetings, Village-related trade shows or meetings, or work-related business. Local travel within Illinois only needs to be approved by an employee’s department head or the Village Manager. Travel that requires private travel and/or lodging or is held out of state must also be approved by the Village Manager ~~approved~~ prior to commencement.

The maximum allowable reimbursement per travel event for travel, ~~meal~~ meals, and lodging expenses will be the greater of a) \$750 for in-state travel, b) \$2,000 for out of state travel, or c) the amount detailed in the adopted budget. If the total reimbursement request exceeds the maximum allowable reimbursement, that request must be approved by roll call vote of the Village Board at an open meeting in compliance with the Local Government Travel Expense Control Act (the “Act”).

No reimbursement shall be allowed for any entertainment expense, which includes, but is not limited to, shows, amusements, theaters, circuses, sporting events, or any other place of public or private entertainment or amusement, unless ancillary to the purpose of the program or event. Expenses for travel, meals, and lodging for the Village President or any member of the Village Board may only be approved by roll call vote at an open meeting of the Village Board.

Any travel advance will be processed with a Check Request form. Travel advances will require a Travel Request form to be filled out, approved, and attached to the Check Request. If travel required private travel and/or lodging or was held out of state, ~~the~~ Travel Request form is to be completed after the trip and returned with all required receipts attached.

Travelers will be cost-conscious for travel, local transportation, and lodging.

Meal expenses during travel should not be charged to the Village’s purchasing card. Meals will be reimbursed to the employee after the receipts have been submitted, and only for meals that are not already provided with conference registration. Meals will be reimbursed up to \$10 for breakfast, \$15 for lunch, and \$25 for dinner (tip is included in these amounts). Alcohol beverages will not be reimbursed. Employees will be required to return travel advances that exceed submitted receipts.

Mileage may be reimbursed when the use of a Village vehicle is not reasonable. Employees will carpool to an event whenever practical and reasonable. Reimbursement rate will be the rate established by the IRS. When travelling from home for Village business, the miles normally travelled on an employee’s regular commute will offset the miles travelled for reimbursement.

Employees covered by the labor agreements shall be governed by their respective contracts then in effect for purposes of calculating meals. Provisions of contracts in conflict with the Local Government Travel Expense Control Act shall be governed by State law.



MEMORANDUM

TO: Village of Villa Park Board of Trustees
Michael Rivas, Village Manager

FROM: Tim Howe, Director of Parks & Recreation
Brian Roche, Superintendent of Parks, Buildings and Grounds

DATE: April 7, 2026

SUBJECT: Building Automation HVAC Control System Replacement Needed at the Police Department facility located at 40 S Ardmore Ave.

RECOMMENDED ACTION

Staff requests authorization to replace the HVAC control system at the Police Department at 40 S Ardmore Ave in an amount not to exceed \$43,756. Funding for this project will be taken from the 2026 Building Fund Capital Budget, GL 11-206-540102.

BACKGROUND

The building automation control system at the Police Department has failed and is no longer operational and able to be supported. This system controls all the HVAC systems and components for the facility. This system is critical in maintaining safe operation of heating, cooling, and ventilation for the facility and staff. The new system we are looking to install will be internet based and able to make adjustments to the system via internet (remotely) rather than going to the police department and physically changing the system.

The Village worked quickly and solicited proposals from 2 companies and received 2 proposals back, the low estimate for this work is with C. Acitelli Heating and Piping Contractors, Inc. of Villa Park, Illinois in the amount of \$43,756. Staff recommend moving forward with C. Acitelli Heating and Piping Contractors, Inc. for the purchase and installation of a new Distech Eclipse system as described in proposal 031226-01.

C. Acitelli Heating and Piping Contractors, Inc., who have submitted the lowest proposal, are very familiar with the Police Department HVAC systems as they have provided emergency services to our systems and 7 repair calls over the past 6 years. Acitelli also completed the boiler replacement at the Police Department in 2019 when that system failed. Current lead time is three-to-five-days on equipment, and installation is estimated at one week. If approved we could see install start as early as the end of April, which would allow the system to be operational again before warm temps may affect facility and staff.

Staff also request authorization to waive the requirement of open and competitive bidding so the units can be ordered and received quickly as time is of the essence to complete repairs before temperatures increase. Section 2-220(a)(3) of the Villa Park Municipal Code provides an exemption from bidding requirements for contracts where the corporate authorities by a two thirds affirmative vote waive the requirement of open and competitive bidding. If open and competitive bidding is requested for this project it would push ordering and receiving the units back significantly, into late May or possibly later depending on availability. The installation would then likely be into June or later depending on equipment availability.

RESOLUTION NO. _____

**RESOLUTION OF THE VILLAGE OF VILLA PARK, DUPAGE COUNTY, ILLINOIS,
APPROVING THE PROPOSAL OF C. ACITELLI HEATING & PIPING
CONTRACTORS, INC., FOR THE PURCHASE AND INSTALLATION OF
REPLACEMENT HVAC BUILDING AUTOMATION SYSTEM FOR THE POLICE
DEPARTMENT IN AN AMOUNT NOT TO EXCEED \$43,756.00.**

WHEREAS, the Village of Villa Park, DuPage County, Illinois (the “Village”) is a duly organized and validly existing non-home rule municipality created in accordance with the Constitution of the State of Illinois of 1970 and the laws of the State of Illinois; and

WHEREAS, Section 2-220(a)(3) of Division 2 of Article II of Chapter 2 of the Villa Park Municipal Code exempts from the competitive bidding requirements purchase orders or contracts of whatever nature, for labor, services of work, where the Board of Trustees, by a two-thirds majority affirmative vote of its members, waive the requirement of open and competitive bidding; and

WHEREAS, the President and Board of Trustees of the Village have determined that it is advisable, necessary and in the best interests of the public that the Village waive competitive bidding and accept the proposal submitted by C. Acitelli Heating & Piping Contractors, Inc., for the purchase and installation of Replacement HVAC Building Automation System for the Village Police Department in an amount not to exceed \$43,756.00.

NOW, THEREFORE, BE IT RESOLVED by the President and Board of Trustees of the Village of Villa Park, DuPage County, State of Illinois, as follows:

Section 1: The facts and statements contained in the preamble to this Resolution are found to be true and correct and are hereby adopted as part of this Resolution.

Section 2: That the corporate authorities of the Village hereby approve the proposal submitted by C. Acitelli Heating & Piping Contractors, Inc., dated March 12, 2026, for the purchase and installation of Replacement HVAC Building Automation System for the Village Police Department ("Proposal"), said Proposal being attached hereto as “Exhibit A” and incorporated herein, and the Village Manager is hereby authorized to accept the Proposal, issue a

purchase order and execute all other necessary documents related to the purchase and installation of the HVAC Building Automation System or such other comparable units, in an amount not to exceed \$43,756.00.

Section 3: That the competitive bidding requirements are waived in accordance with Section 2-220 of Division 2, of Article II, of Chapter 2 of the Villa Park Municipal Code.

Section 4: The officials, officers, employees, and attorneys of the Village are hereby authorized to take such further actions as are necessary to carry out the intent and purpose of this Resolution and the Agreement.

Section 5: All work performed pursuant to this Resolution shall comply with applicable federal, state, and local laws, regulations, and Village codes.

Section 6: If any section, paragraph, or provision of this Resolution shall be held to be invalid or unenforceable, the invalidity thereof shall not affect any of the other provisions of this Resolution.

Section 7: All ordinances, resolutions, motions or orders in conflict with this Resolution are hereby repealed to the extent of such conflict.

Section 8: That this Resolution shall be in full force and effect from and after its passage by a two-thirds vote of the Village Board and approval according to law.

PASSED this ____ day of April, 2026, pursuant to a roll call vote as follows:

AYES: ____

NAYS: ____

ABSENT: ____

ABSTAIN: ____

APPROVED ____ day of April, 2026.

Kevin Patrick, Village President

Attest:

Rolf Laukant, Village Clerk

Dated this ____ day of April, 2026.

Exhibit A

C. Acitelli Heating & Piping Contractors, Inc. Proposal

PROPOSAL

SUBMITTED TO:

COMPANY: Village of Villa Park
 ADDRESS: 20 S Ardmore Ave
 Villa Park, IL 60181
 ATTN: Brian Roche
 EMAIL: broche@invillapark.com

JOB INFORMATION:

RE: Building Automation System Replacement
 LOCATION: Villa Park Police Department
 40 S Ardmore Ave
 PHONE: 630-327-1146 FAX:
 QUOTE # 031226-01 DATE: 3/12/2026

Please consider this a proposal to remove existing Honeywell Jace which is no longer operational, (24) existing Staefa and Honeywell old LON based controllers with new Distech Eclpse system. System to include (22) Eclpse VAV Controllers, (2) main controllers for existing roof top unit and boiler plant. New control system to be BacNet communication protocol as existing LON devices are being phased out and no longer supported. Installation to include the following:

- Qty. 1 – Eclpse connected system controller (ECY-S1000) including power supply, connectivity server, and communication module.
- Qty. 2 – Eclpse connected controllers (ECY-303) serving boiler plant and rooftop unit.
- Qty. 22 – Eclpse connected VAV controllers (ECY-VAV).
- Qty. 22 – Allure EC-SMART sensors (EC-SMART-COMFORT-S).
- Qty. 22 – Mamac Discharge Air Sensors.
- Qty. 1 – Mamac Outside Air Sensor
- All necessary Cat5 cabling to connect all controllers back to Eclpse network server.
- All necessary Cat5 connections for thermostats to controllers.
- All necessary routers/switches.
- All necessary programming, testing and startup.
- All necessary labor and materials to complete job in a satisfactory manner.
- C. Acitelli shall guarantee all labor and material for a period of one year.
- Distech includes a two-year hardware warranty.
- All work to be performed during normal working hours, Monday-Friday, 7:00am to 3:30pm.
- Our price does not include any permits, bonds, or fees.

OUR PRICE FOR THE ABOVE:

Forty-three thousand seven hundred fifty-six and 00/100

DOLLARS **\$43,756.00**

Any alteration or deviation from above specifications involving extra costs will be executed only upon written orders and will become an extra charge over and above the estimate.

Acceptance of Proposal – The above prices and specifications are satisfactory and are hereby accepted. You are authorized to do work.

This price/proposal is valid for 30 days.

**Authorized
Signature**

Charles Acitelli, Jr.

Signature _____

Name _____

Date _____

PROPOSAL

SUBMITTED TO:

COMPANY: Village of Villa Park
 ADDRESS: 20 S Ardmore Ave
 Villa Park, IL 60181
 ATTN: Brian Roche
 EMAIL: broche@invillapark.com

JOB INFORMATION:

RE: Building Automation System Replacement
 LOCATION: Villa Park Police Department
 40 S Ardmore Ave
 PHONE: 630-327-1146 FAX:
 QUOTE # 031226-01 DATE: 3/12/2026

Please consider this a proposal to remove existing Honeywell Jace which is no longer operational, (24) existing Staefa and Honeywell old LON based controllers with new Distech Eclypse system. System to include (22) Eclypse VAV Controllers, (2) main controllers for existing roof top unit and boiler plant. New control system to be BacNet communication protocol as existing LON devices are being phased out and no longer supported. Installation to include the following:

- Qty. 1 – Eclypse connected system controller (ECY-S1000) including power supply, connectivity server, and communication module.
- Qty. 2 – Eclypse connected controllers (ECY-303) serving boiler plant and rooftop unit.
- Qty. 22 – Eclypse connected VAV controllers (ECY-VAV).
- Qty. 22 – Allure EC-SMART sensors (EC-SMART-COMFORT-S).
- Qty. 22 – Mamac Discharge Air Sensors.
- Qty. 1 – Mamac Outside Air Sensor
- All necessary Cat5 cabling to connect all controllers back to Eclypse network server.
- All necessary Cat5 connections for thermostats to controllers.
- All necessary routers/switches.
- All necessary programming, testing and startup.
- All necessary labor and materials to complete job in a satisfactory manner.
- C. Acitelli shall guarantee all labor and material for a period of one year.
- Distech includes a two-year hardware warranty.
- All work to be performed during normal working hours, Monday-Friday, 7:00am to 3:30pm.
- Our price does not include any permits, bonds, or fees.

OUR PRICE FOR THE ABOVE:

Forty-three thousand seven hundred fifty-six and 00/100

DOLLARS **\$43,756.00**

Any alteration or deviation from above specifications involving extra costs will be executed only upon written orders and will become an extra charge over and above the estimate.

Acceptance of Proposal – The above prices and specifications are satisfactory and are hereby accepted. You are authorized to do work.

This price/proposal is valid for 30 days.

Authorized Signature

Charles Acitelli, Jr.

Signature _____

Name _____

Date _____

ECY-S1000 Series

Control, Automation, and
Connectivity Servers



Overview

The ECY-CSC is sized to cost-effectively meet the requirements of any HVAC application from small to medium to large systems. The most capable Connected System Controller model can be expanded to support up to 20 input/output (I/O) modules (up to 320 I/Os) while being able to adapt to new requirements as the need arises.

A connecting cable is used to connect successive rows of modules within a controls' cabinet to provide power and communication.

Features & Benefits

- Support for a range of communication protocols such as BACnet MS/TP, Modbus RTU, Modbus TCP, and M-Bus
- With the RESTful API, data can be accessed from different applications, such as energy dashboards, analytics tools, and mobile applications
- Expandable as needs increase to support up to 20 input/output (I/O) modules (up to 320 I/Os)
- Integrates up to three RS-485 ports
- Lighting and shade/sunblind expansion modules to control lights and shades/sunblinds
- Compatible with Distech Controls line of *Bluetooth*[®] low energy technology enabled devices and mobile application providing state-of-the-art occupant management
- Multi-sensor compatibility combines motion and luminosity (Lux) sensors
- Available remote access to program, configure, or maintain the installation, reducing costs associated with on-site visits
- Terminal blocks are uniquely identified and color-coded for clarity and to prevent wiring mistakes
- Embedded alarms, trend log and schedule support allows for fully distributed data and logic
- Automatic email notifications for system status and alarms to ensure faster system servicing and response time

Model Selection

Example: ECY-S1000**E-28-MS**

Series ^a	WebServer	License Points Limit	BACnet MS/TP Routing
ECY-S1000	[blank] : No Embedded Graphics E : With Embedded Graphics	-28 : 28 Points HW (3 Modbus) -48 : 48 Points HW (10 Modbus) [blank] : No Limits (320 typ., 96 Modbus)	[blank] : No BACnet MS/TP Routing Option -MS : With BACnet MS/TP Routing ^b

^aSEP models (single Ethernet port) have secondary Ethernet port factory disabled

^bOption already included in no limits license, please specify [blank]

Accessories

Eclipse Wi-Fi Adapter	Wi-Fi Adapter for Eclipse Connected Controllers.
Eclipse Open-To-Wireless™ Adapter	EnOcean communication protocol adapter for Eclipse Connected Controllers.
Eclipse HD15 Cable	6ft (1.8m) cable for multiple-row panel installations. An HD15 cable must always be followed by a power supply module. For more information, refer to the Hardware Installation Guide.
ECx-Subnet-Adapter	Required for daisy-chaining the ECx-Display or the EC-Multi-Sensor with other subnet devices

Product Specifications

Power Supply Input

Voltage	18VDC
Power Consumption	8.9W; external loads excluded

Wireless Adapter	Optional, USB Port Connection Refer to the Eclipse Wi-Fi Adapter Spec Sheet
Wi-Fi Frequency	2.4 GHz / 5 GHz

Communications

Ethernet Connection Speed	10/100 Mbps
Cable Type	Cat 5e, 8 conductor twisted pair (unshielded)
Addressing	IPv4 or Hostname
BACnet Profile	BACnet Building Controller (B-BC)
BACnet Listing	BTL (B-BC)
BACnet Interconnectivity	BBMD forwarding capabilities BACnet MS/TP to BACnet/IP and BACnet/SC routing
BACnet Transport Layer	IP, BACnet/SC (Node) & MS/TP (optional)
Web Server Protocol	HTML5
Web Server Application Interface	REST API
BACnet MS/TP or Modbus RTU	1 × RS-485 serial communications ports
RS-485 Wiring	1-pair + Common/shield
RS-485 EOL Resistor	Built-in
RS-485 Baud Rates	9600, 19 200, 38 400, or 76 800 bps
RS-485 Addressing	Controller's Web Configuration Interface
Modbus TCP	Devices must be on the same subnet

Subnetwork

Communication	RS-485
Cable Type	Cat 5e, 8 conductor twisted pair
Connector	RJ-45
Connection Topology	Daisy-chain
Maximum number of standard room devices supported per controller combined ^a	12
Allure EC-Smart-Vue Series ^b	12
Allure EC-Smart-Comfort Series	6
Allure EC-Smart-Air Series ^b	6
EC-Multi Sensor	4
ECx-Light-4 / ECx-Light-4D / ECx-Light-4DALI	2
ECx-Blind-4 / ECx-Blind-4LV / ECx-Blind-4SMI / ECx-Blind-4SMI-LoVo	2
Maximum number of Bluetooth low energy room devices per controller combined ^c	6
Allure Unitouch™	2
EC-Multi-Sensor-BLE	4

^aFor more details about supported quantities, see the Product Selection Tool available in Builder: <https://builder.distech-controls.com>.

^bA controller can support a maximum of 2 Allure sensor models equipped with a CO₂ sensor. Any remaining connected sensors must be without a CO₂ sensor.

^cA mixed architecture with standard room devices and Bluetooth low energy enabled devices is not recommended.

Hardware

Processor	Sitara ARM processor
CPU Speed	1GHz
Memory	4GB Non-volatile Flash (applications & storage) 512MB RAM
Real Time Clock (RTC)	Real Time Clock with rechargeable battery Supports SNTP network time synchronization
RTC Battery	20 hours charge time, 20 days discharge time Up to 500 charge / discharge cycles
Cryptographic Module	FIPS 140-2 Level 1 Compliant
Ethernet	2 switched RJ-45 Ethernet ports (Supported Protocols: BACnet/IP, Modbus TCP, NTP, and REST)
USB Connections	2 × USB 2.0 Ports 1 × Micro-USB 2.0 Ports
RS-485 Serial Communications	Screw terminals (Supported Protocols: BACnet MS/TP or Modbus RTU)
Subnet	RJ-45
Green LED	Power status, Subnet TX, RS-485 TX, and Ethernet Traffic
Orange LED	Controller status, Subnet RX, RS-485 RX, and Ethernet Speed

Open-to-Wireless Adapter

Communication Protocol	EnOcean wireless standard ^a
Connector Type	USB
Number of Wireless Inputs	Unlimited ^b



^aAvailable when an optional external Eclipse Open-to-Wireless Adapter is connected to the controller. Refer to the Open-to-Wireless Application Guide for a list of supported EnOcean wireless modules.

^bWireless inputs will only be limited by physical distance between the EnOcean devices and the Eclipse Open-to-Wireless Adapter.

Mechanical

Dimensions (H × W × D)	4.74 × 3.57 × 2.31" (120.31 × 90.67 × 58.56mm)
Shipping weight	0.85lbs (0.39kg)
Mounting	DIN rail or screw mounting
Enclosure Material	FR/ABS
Enclosure Rating ^a	Plastic housing, UL94-V0 flammability rating

^aAll materials and manufacturing processes comply with the RoHS directive and are marked according to the Waste Electrical and Electronic Equipment (WEEE) directive

Environmental

Operating Temperature	32 to 122°F (0 to 50°C)
Storage Temperature	-22 to 158°F (-30 to 70°C)
Relative Humidity	0 to 90% non-condensing
Ingress Protection Rating	IP20
Nema Rating	1

Standards and Regulations

CE Emission	EN61000-6-3: 2007+A1:2011
CE Immunity	EN61000-6-1: 2007
FCC	Compliance with FCC rules part 15, subpart B, class B
UL Listed (CDN & US)	UL916 Energy management equipment



Dimensions

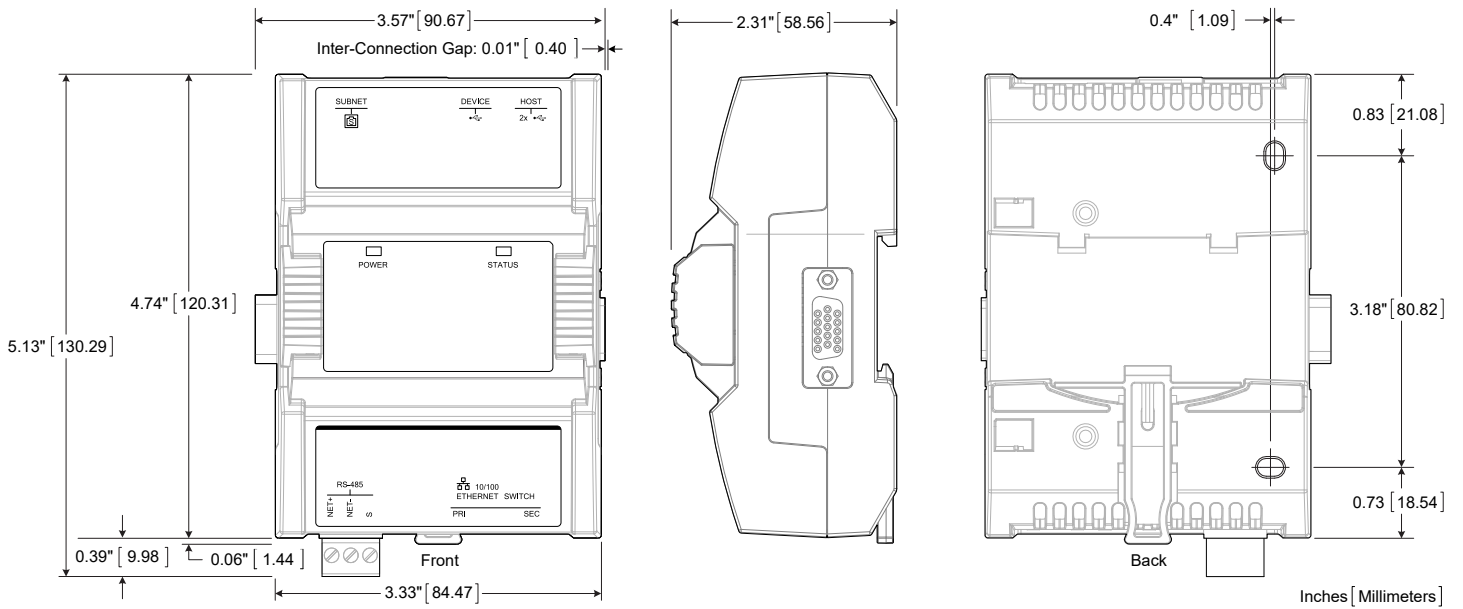

ECY-S1000 Dimensions

Specifications subject to change without notice.

Eclipse, Distech Controls, the Distech Controls logo, EC-Net, Allure, and Allure UNITOUCH are trademarks of Distech Controls Inc. BACnet is a registered trademark of ASHRAE; BTL is a registered trademark of the BACnet Manufacturers Association. The Bluetooth® word mark and logos are registered trademarks owned by Bluetooth SIG, Inc. and any use of such marks is under license. All other trademarks are property of their respective owners.

©, Distech Controls Inc., 2025 All rights reserved.

Global Head Office - 4205 place de Java, Brossard, QC, Canada, J4Y 0C4 - EU Head Office - ZAC de Sacuny, 558 avenue Marcel Mérieux, 69530 Brignais, France

Eclipse™ Power Supply Modules (ECY-PS)



Overview

The Connected System Controller's recurrent power supply concept can be used when more power is required to power a series of I/O modules. A 100 to 240VAC power supply module eliminates the need for a line voltage to 24VAC power transformer to save installation costs and time. A 24 VAC / VDC power supply module is equally available.

Features & Benefits

- Recurrent power supply concept can be used when more power is required to power a series of I/O modules
- 100 to 240VAC power supply module eliminates the need for a line voltage to 24VAC power transformer to save installation costs and time
- Uses the latest high-efficiency switch-mode circuitry to make more power available to operate additional modules and for cooler operation
- Over-voltage and over-current output protection to protect the electronics in unstable power supply conditions and against mis-wiring

Model Selection

Example: ECY-PS24

Series	Power Supply
ECY-PS	24 : 24VAC/VDC 100-240 : 100 to 240VAC

Product Specifications ECY-PS24

Power Supply Input

Input Voltage Range	24VAC/DC; ±15%; Class 2
Input Power Consumption	60VA
Input Frequency Range	50 to 60Hz
Overcurrent Protection	Field replaceable fuse
Fuse Type	4A, fast-acting, 5 × 20mm (GMA-4A)

Shipping Weight	0.75lbs (0.34kg)
Mounting	DIN rail or screw mounting
Enclosure Material ¹	FR/ABS
Enclosure Rating	Plastic housing, UL94-V0 flammability rating

¹All materials and manufacturing processes comply with the RoHS directive and are marked according to the Waste Electrical and Electronic Equipment (WEEE) directive

Power Supply Output

DC Voltage Output	18VDC regulated
Rated Current Output Range	0 to 1.6A
Rated Power Output	30W ¹

¹The total power consumption of all modules connected to the right of this power supply, and up to the next connected power supply, including any connected loads, must be less than this value. A separate transformer rated at 60VA minimum and 100VA maximum must be used for each ECY-PS24 power supply for it to operate at full capacity.

Environmental

Operating Temperature	32 to 122°F (0 to 50°C)
Storage Temperature	-22 to 158°F (-30 to 70°C)
Relative Humidity	0 to 90% non-condensing
Ingress Protection Rating	IP20
Nema Rating	1

Hardware

Power Distribution Direction	Powered modules are connected to the right
Backplane Bus	Pass-through connection for data and control signals
Status Indicator	Green LED: power status

Standards and Regulations

CE Emission	EN61000-6-3: 2007; A1:2011
CE Immunity	EN61000-6-1: 2007
CE	This device complies with FCC rules part 15, subpart B, class B
UL Listed (CDN and US)	UL916 Energy management equipment

Mechanical

Dimensions (H × W × D)	4.74 × 2.85 × 2.31" (120.31 × 72.38 × 58.56mm)
------------------------	--



Product Specifications ECY-PS100-240

Power Supply Input

Input Voltage Range	100 to 240 VAC Universal; +10%/-15%
Input Current	400mA typical
Input Frequency Range	50 to 60Hz
Standby Power Consumption	<0.5W

Overcurrent Protection	Field replaceable fuse
Fuse Type	2.5A, Fast-acting, high-breaking, 250VAC, 5 × 20mm (TF2.5AH250V, IEC60127-2)

Power Supply Output

DC Voltage Output	18VDC regulated
Rated Current Output Range	0 to 2A
Rated Power Output	40W ¹

¹The total power consumption of all modules connected to the right of this power supply, and up to the next connected power supply, including any connected loads, must be less than this value.

Hardware

Power Distribution Direction	Powered modules are connected to the right
Backplane Bus	Pass-through connection for data and control signals
Status Indicator	Green LED: power status

Mechanical

Dimensions (H × W × D)	4.74 × 4.08 × 2.31" (120.31 × 103.65 × 58.56mm)
Shipping Weight	0.71lbs (0.32kg)
Mounting	DIN rail or screw mounting
Enclosure Material ¹	FR/ABS
Enclosure Rating	Plastic housing, UL94-V0 flammability rating

¹All materials and manufacturing processes comply with the RoHS directive and are marked according to the Waste Electrical and Electronic Equipment (WEEE) directive

Environmental

Operating Temperature	32 to 122°F (0 to 50°C), 0 to 90% non-condensing
Storage Temperature	-22 to 158°F (-30 to 70°C)
Relative Humidity	0 to 90% non-condensing
Altitude	<6562ft (2000m)
Ingress Protection Rating	IP20 (must be mounted in a protective enclosure to conform with electrical installation standards)
Pollution Degree	2
Overvoltage	Category II - 2.5 kV
Electrical Protection	DC output is Separated Extra-Low Voltage (SELV); SELV is implemented through reinforced insulation

Standards and Regulations

CE Electrical Safety	EN 60730-1 : 2011
CE Emission	EN61000-6-3: 2007; A1:2011
CE Immunity	EN61000-6-1: 2007
FCC	This device complies with FCC rules part 15, subpart B, class B
UL Listed (CDN and US)	UL 61010-1



Dimensions

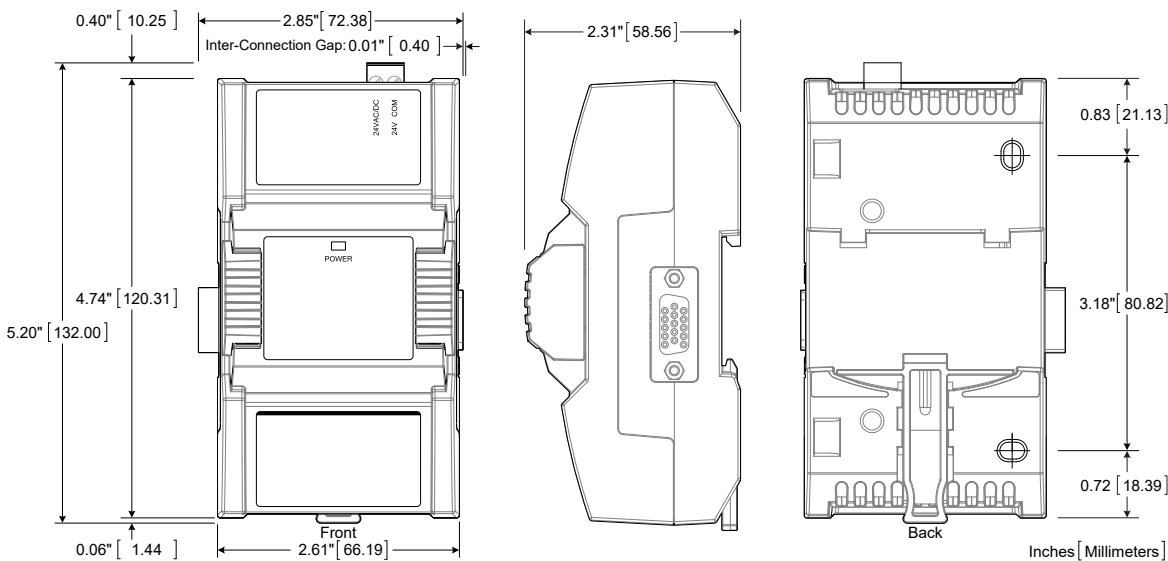

ECY-PS24 Power Supply Dimensions US & SI

Specifications subject to change without notice.

Eclipse, Distech Controls, the Distech Controls logo, EC-Net, Allure, and Allure Unitouch are trademarks of Distech Controls Inc. BACnet is a registered trademark of ASHRAE; BTL is a registered trademark of the BACnet Manufacturers Association. The Bluetooth® word mark and logos are registered trademarks owned by Bluetooth SIG, Inc. and any use of such marks is under license. All other trademarks are property of their respective owners.

©, Distech Controls Inc., 2025 All rights reserved.

Global Head Office - 4205 place de Java, Brossard, QC, Canada, J4Y 0C4EU Head Office - ZAC de Sacuny, 558 avenue Marcel Mériex, 69530 Brignais, France

Eclipse Communication Modules



Overview

Communication modules enable Eclipse Connected Controllers to communicate with a variety of devices.

The ECY-RS485 communication module adds two extra RS-485 trunks to support more BACnet MS/TP and Modbus RTU devices.

An ECY-MBUS communication module adds one M-Bus port to support and power up to 60 M-Bus meters.

Features & Benefits

- Multiple communication protocols, like BACnet/IP and Modbus, make it easier to integrate into existing building automation systems and add functionality for edge applications such as metering.
- Easier communication module setup through the same web interface as the Eclipse connected controllers.
- The communications modules are plug & play devices and are equipped with HD-15 connectors that transmit power and communication to the next module for fast and easy assembly.
- The status LEDs on the communications modules allows the user to confirm the status of the inputs/outputs and facilitate commissioning and troubleshooting.
- Supports Distech Controls' EC-*gfx*Program, which makes Building Automation System (BAS) programming effortless, by allowing you to visually assemble building blocks to create a custom control sequence for any HVAC, lighting, or building automation application.

Model Selection

Model	Description
ECY-RS485 Gen2	Communication module with two RS-485 ports for Eclipse Facilities controllers. Supports Modbus RTU and BACnet MS/TP. Requires Eclipse Connectivity Pack (1 MS/TP device per connection or two ModBus devices per connection). Minimum one connection required to enable BACnet MS/TP routing.
ECY-MBUS Gen2	Communication module with one M-Bus port for Eclipse Facilities controllers (up to 60 M-Bus meters). Requires Eclipse Connectivity Pack (8 M-Bus meters per connection).
ECY-RS485	Eclipse Communication module with two RS-485 ports for Modbus RTU or BACnet MS/TP with a Generation 1 Eclipse connected controller.
ECY-MBUS	Eclipse Communication module with one M-Bus port, supporting up to 60 physical M-Bus meters when connected to an Generation 1 Eclipse connected controller, or up to 3 physical meters when connected via USB to an ECY-VAV, ECY-303, or ECY-(P)TU.

Product Specification ECY-RS485

Supported Quantity	1 × ECY-RS485 per Eclipse connected controller	Mounting	DIN rail or screw mounting
		Enclosure Material	FR/ABS
		Enclosure Rating ¹	Plastic housing, UL94-V0 flammability rating
Power Supply Input			
Voltage	18VDC; Class 2		
Power Consumption	1.5 W		
			¹ All materials and manufacturing processes comply with the RoHS directive and are marked according to the Waste Electrical and Electronic Equipment (WEEE) directive
Communications		Environmental	
BACnet MS/TP or Modbus RTU	2 × RS-485 serial communication ports Each RS-485 port supports one communication protocol at a time	Operating Temperature	32 to 122°F (0 to 50°C)
RS-485 Wiring	1-pair + Common/shield	Storage Temperature	-22 to 158°F (-30 to 70°C)
Connection Type	Screw terminals	Relative Humidity	0 to 90% non-condensing
RS-485 EOL Resistor	Built-in	Ingress Protection Rating	IP20 in accordance with IEC 60537
RS-485 Baud Rates	9600, 19 200, 38 400, or 76 800 bps	Nema Rating	1
RS-485 Addressing	Controller's Web Configuration Interface		
Status Indicators	Green LED: TX Orange LED: RX	Standards and Regulations	
		CE Emission	EN61000-6-3: 2007; A1:2011
		CE Immunity	EN61000-6-1: 2007
		FCC	Compliance with FCC rules part 15, subpart B, class B
		UL Listed (CDN & US)	UL916 Energy management equipment
Mechanical			
Dimensions (H × W × D)	4.74 × 3.20 × 2.31" (120.31 × 81.17 × 58.56mm)		
Shipping weight	0.69lbs (0.31 kg)		



Dimensions ECY-RS485

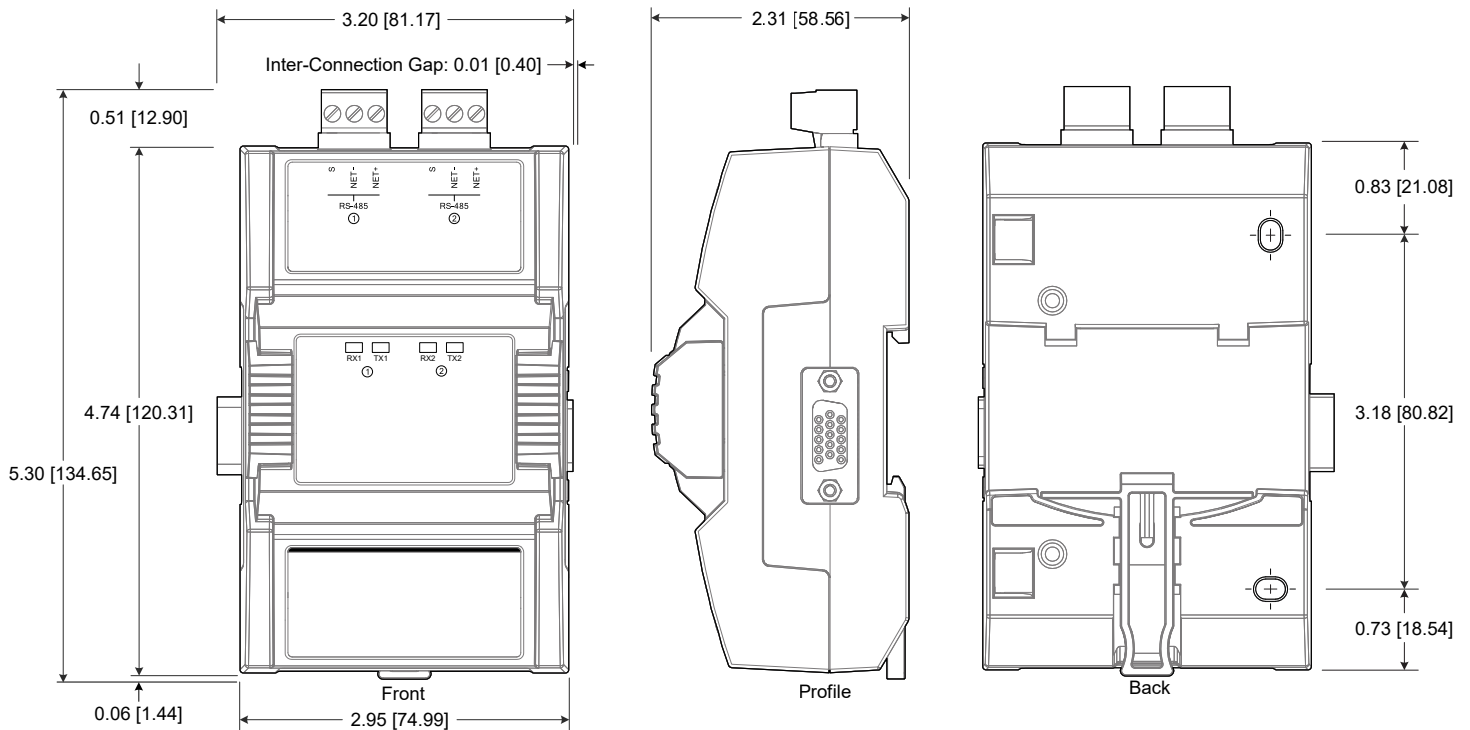

ECY-RS485 Dimensions (Inches [millimeters])

Product Specification ECY-MBUS

Supported Quantity	1 × ECY-MBUS per Eclipse connected controller	Status Indicators	Green LED: TX Orange LED: RX Green LED: POWER Red LED: MBUS Fault
Power Supply Input		Mechanical	
Power Source	ECY-PS24 or ECY-PS-100-240 power supply module, or USB port	Dimensions (H × W × D)	4.74 × 3.20 × 2.31" (120.31 × 81.17 × 58.56mm)
Voltage	18V; Class 2 (when equipped) 5V; Class 2 (when connected via USB)	Shipping weight	0.69lbs (0.31 kg)
Power Consumption	10W over 18V power supply 2.5W over USB	Mounting	DIN rail or screw mounting
Communications		Enclosure Material	FR/ABS
M-Bus Ports	1x M-Bus serial communication port	Enclosure Rating ¹	Plastic housing, UL94-V0 flammability rating
Supported Physical M-Bus Meters	3 (USB), or 60 (ECY-MBUS60)	¹ All materials and manufacturing processes comply with the RoHS directive and are marked according to the Waste Electrical and Electronic Equipment (WEEE) directive	
M-Bus Wiring Terminals	2	Environmental	
M-Bus baud rates	300, 600, 900, 1200, 2400, 4800, and 9600	Operating Temperature	32 to 122°F (0 to 50°C)
M-Bus Meter Addressing	Configured in EC-gfxProgram	Storage Temperature	-22 to 158°F (-30 to 70°C)
		Relative Humidity	0 to 90% non-condensing
		Ingress Protection Rating	IP20 in accordance with IEC 60537
		Nema Rating	1

Standards and Regulations

UL Listed (CDN & US)

UL916 Energy management equipment

CE Emission
CE Immunity
FCC

EN61000-6-3: 2007; A1:2011
EN61000-6-1: 2007
Compliance with FCC rules part 15, subpart B, class B



Dimensions ECY-MBUS

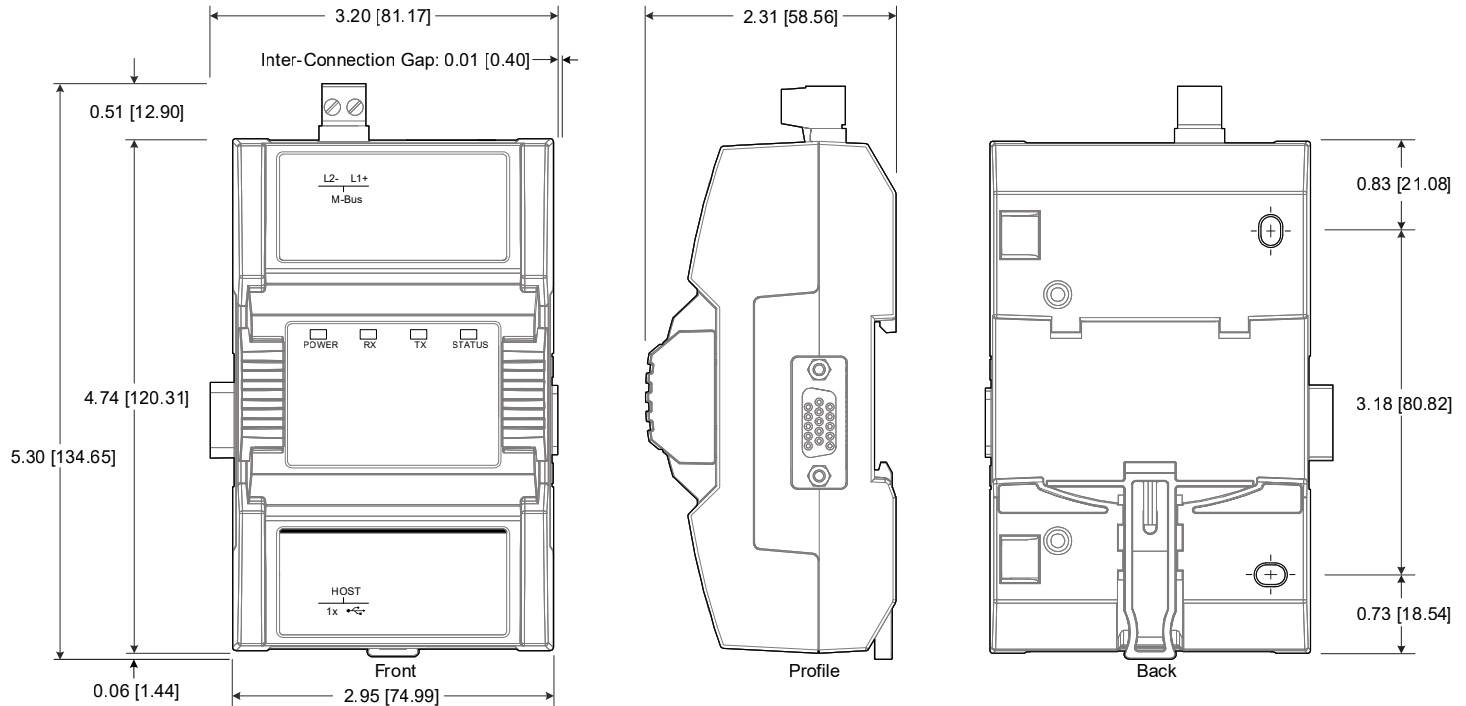

ECY-MBUS Dimensions (Inches [Millimeters])

Specifications subject to change without notice.

Eclipse, Distech Controls, the Distech Controls logo, EC-Net, Allure, and Allure UNITOUCH are trademarks of Distech Controls Inc. BACnet is a registered trademark of ASHRAE; BTL is a registered trademark of the BACnet Manufacturers Association. The Bluetooth® word mark and logos are registered trademarks owned by Bluetooth SIG, Inc. and any use of such marks is under license. All other trademarks are property of their respective owners.

©, Distech Controls Inc. All rights reserved., 2025 All rights reserved.

Global Head Office - 4205 place de Java, Brossard, QC, Canada, J4Y 0C4 - EU Head Office - ZAC de Sacuny, 558 avenue Marcel Mérieux, 69530 Brignais, France

ECLYPSE™ Connected Equipment Controller

ECLYPSE™



Overview

The ECLYPSE Connected Equipment Controller (ECY-303) is designed to satisfy the needs of a wide range of HVAC applications such as small and medium terminal applications. It integrates a control, automation and connectivity server, power supply, and I/O in one convenient package. It supports BACnet/IP communications and is a listed BACnet Building Controller (B-BC). In addition, the ECY-303-M3 model supports Modbus to connect to meters, Variable Frequency Drives, etc.

This programmable controller comes with an embedded web server that enables web-based application configuration and a visualization interface. It also features embedded scheduling, alarming, and logging. Control logic and graphic user interface can be customized as required for the application.

Features & Benefits

- Utilizes BACnet/IP and IT standards, delivering empowered IP connectivity and open integration with building management systems
- Uses cryptographic modules making it FIPS 140-2 "Inside"
- Via its RESTful API, data can be accessed from different applications, such as energy dashboards, analytics tools, and mobile applications
- Comes with ECLYPSE Designer Viewer and the associated pre-loaded rooftop unit applications and graphics pre-installed
- xpressENVYSION offers a simplified and streamlined experience in a workflow oriented, drag & drop GUI environment
- Supports EC-gfxProgram, which makes Building Automation System (BAS) programming effortless
- Supports both Modbus TCP & Modbus RTU devices
- Supports Smart Room Control for an end-to-end system for the control of HVAC equipment, lighting, and shades/sunblinds
- The status LEDs allow the user to confirm the status of the inputs/outputs and facilitate commissioning and troubleshooting
- Embedded alarms, trend log and schedule support allows for fully distributed data and logic providing a more robust system. Embedded trend logs simplify system troubleshooting when compared to a centralized system
- Automatic email notifications for system status and alarms to ensure faster system servicing and response time

Model Selection

Example: ECY-303-**M3 (SI)**

Series ¹	Modbus TCP & RTU Devices	Units
ECY-303	[blank] : No Modbus TCP & RTU device support -M3 : Supports up to 3 Modbus TCP & RTU devices	(SI) : Preloaded Apps in SI (Metric) units (IMP) : Preloaded Apps in Imperial (US) units
16-points, 8 UI, 2 UO, 4 DO, 2 DUO, 18 Vdc power supply, ENVYISION Viewer		

1. SEP models (single Ethernet port) have secondary Ethernet port factory disabled

Accessories

ECLYPSE Wi-Fi Adapter	Wi-Fi Adapter for ECLYPSE Connected Controllers.
ECLYPSE Open-To-Wireless™ Adapter	EnOcean communication protocol adapter for ECLYPSE Connected Controllers.

Product Specifications

Power Supply Input

Voltage Range ¹	24VAC/DC; ±15%; Class 2
Nominal Power Consumption	18VA; all external loads excluded, no USB peripherals
Full Load Power Consumption	36VA; external 24VAC loads excluded
Frequency Range	50 to 60Hz
Overcurrent Protection	Field replaceable fuse
Fuse Type	2A, fast-acting, 5 × 20mm (GMA-2A)

1. 24VDC does not support DO (triac outputs).

Communications

Ethernet Connection Speed	10/100 Mbps
Cable Type	Cat 5e, 8 conductor twisted pair (unshielded)
Addressing	IPv4 or Hostname
BACnet Profile	BACnet Building Controller (B-BC)), AMEV AS-A and AS-B
BACnet Listing	BTL, WSP B-BC
BACnet Interconnectivity	BBMD forwarding capabilities BACnet/SC routing (Beta)
BACnet Transport Layer	IP, BACnet/SC (Node; Beta)
Web Server Protocol	HTML5
Web Server Application Interface	REST API
Modbus RTU	1 × RS-485 serial communications port
RS-485 Wiring	1-pair + Common/shield
Modbus TCP	Devices must be on the same subnet
Wireless Adapter	Optional, USB Port Connection
Wi-Fi Communication Protocol	IEEE 802.11b/g/n
Wi-Fi Network Types	Client, Access Point, Hotspot

Subnetwork

Communication	RS-485
Cable Type	Cat 5e, 8 conductor twisted pair
Connector	RJ-45
Connection Topology	Daisy-chain

- For more details about supported quantities, see the Product Selection Tool available in Builder: <https://builder.distech-controls.com>.
- A controller can support a maximum of 2 Allure sensor models equipped with a CO₂ sensor. Any remaining connected sensors must be without a CO₂ sensor.
- A mixed architecture with standard room devices and Bluetooth low energy enabled devices is not recommended.

Maximum number of standard room devices supported per controller combined ¹	4
Allure EC-Smart-View Series ²	4
Allure EC-Smart-Comfort Series	4
Allure EC-Smart-Air Series ²	4
EC-Multi Sensor	4
ECx-Light-4 / ECx-Light-4D / ECx-Light-4DALI ¹	2
ECx-Blind-4 / ECx-Blind-4LV / ECx-Blind4SMI / ECx-Blind-4SMI-LoVo ¹	2
Maximum number of Bluetooth low energy room devices per controller combined ³	4
Allure UNITOUCH™	2
EC-Multi-Sensor-BLE	4

- For more details about supported quantities, see the Product Selection Tool available in Builder: <https://builder.distech-controls.com>.
- A controller can support a maximum of 2 Allure sensor models equipped with a CO₂ sensor. Any remaining connected sensors must be without a CO₂ sensor.
- A mixed architecture with standard room devices and Bluetooth low energy enabled devices is not recommended.

Hardware

Processor	Sitara ARM processor
CPU Speed	600MHz
Memory	4GB Non-volatile Flash (applications & storage) 512MB RAM
Real Time Clock (RTC)	Real Time Clock with rechargeable battery Supports SNTP network time synchronization
RTC Battery	20 hours charge time, 20 days discharge time Up to 500 charge / discharge cycles
Cryptographic Module	FIPS 140-2 Level 1 Compliant
Ethernet	2 switched RJ-45 Ethernet ports (Supported Protocols: BACnet/ IP, Modbus TCP, NTP, and REST)
Integrated fail-safe for daisy-chaining	In case of power failure to one of the controllers, communication data is still relayed to the following controller on the daisy-chain

USB Connections	2 × USB 2.0 Ports 1 × Micro-USB 2.0 Ports
RS-485 Serial Communications	Screw terminals (Supported Protocols: Modbus RTU)
Subnet	RJ-45
Green LED	Power status, Subnet TX, and Ethernet Traffic
Orange LED	Controller status, Subnet RX, and Ethernet Speed

Open-to-Wireless Adapter

Communication Protocol	EnOcean wireless standard ¹
Connector Type	USB
Number of Wireless Inputs	Unlimited ²



1. Available when an optional external ECLYPSE Open-to-Wireless Adapter is connected to the controller. Refer to the Open-to-Wireless Application Guide for a list of supported EnOcean wireless modules.
2. Wireless inputs will only be limited by physical distance between the EnOcean devices and the ECLYPSE Open-to-Wireless Adapter.

Mechanical

Dimensions (H × W × D)	4.74 × 6.78 × 2.31" (120.31 × 172.10 × 58.56 mm)
Shipping weight	1.20lbs (0.55 kg)
Mounting	DIN rail or screw mounting
Enclosure Material ¹	FR/ABS
Enclosure Rating	Plastic housing, UL94-V0 flammability rating

1. All materials and manufacturing processes comply with the RoHS directive and are marked according to the Waste Electrical and Electronic Equipment (WEEE) directive

Environmental

Operating Temperature	-40 to 122°F (-40 to 50°C)
Storage Temperature	-40 to 158°F (-40 to 70°C)
Relative Humidity	0 to 90% non-condensing
Ingress Protection Rating	IP20 (IEC 60549)
Nema Rating	1

Standards and Regulations

CE Emission	EN61000-6-3: 2007+A1:2011
CE Immunity	EN61000-6-1: 2007
FCC	Compliance with FCC rules part 15, subpart B, class B
UL Listed (CDN & US)	UL916 Energy management equipment



Universal Inputs (UI)

General

Input Type	Universal; software configurable
Input Resolution	16-bit analog to digital converter
Power Supply Output	18VDC; 80mA maximum
Protection	Auto-reset fuse for 24VAC protection

Contact

Type	Dry contact
------	-------------

Counter

Type	Dry contact
Maximum Frequency	1Hz maximum
Minimum Duty Cycle	500 ms On / 500 ms Off

0 to 10VDC

Range	0 to 10VDC (40kΩ input impedance)
-------	-----------------------------------

0 to 5VDC

Range	0 to 5VDC (high input impedance)
-------	----------------------------------

0 to 20mA

Range	0 to 20mA, 249Ω external resistor wired in parallel
-------	---

Resistance/Thermistor

Range	0 to 350 KΩ
-------	-------------

Supported Thermistor Types Any that operate in this range

Pre-configured Temperature Sensor Types:

Thermistor	10KΩ Type 2, 3 (10KΩ @ 77°F; 25°C)
Platinum	Pt1000 (1KΩ @ 32°F; 0°C)
Nickel	RTD Ni1000 (1KΩ @ 32°F; 0°C) RTD Ni1000 (1KΩ @ 69.8°F; 21°C)

Universal Outputs (UO)

General

Output Type	Universal; software configurable
Output Resolution Converter	10-bit digital to analog Converter
Output Protection,	Built-in snubbing diode to protect against back-EMF, for example when used with a 12VDC relay
	Output is internally protected against short circuits
Auto-reset Fuse	Provides protection from accidental 24VAC connection

0 or 12VDC (On/Off)

Range	0 or 12VDC
Source Current	Maximum 20 mA at 12VDC (minimum resistance 600Ω)

PWM

Range	Adjustable period from 2 to 65 seconds
-------	--

Thermal Actuator Management Adjustable warm up and cool down time

Floating

Minimum Pulse On/Off Time	500 milliseconds
Drive Time Period	Adjustable

0 to 10VDC

Source:

Voltage Range	0 to 10VDC linear
Source Current	Maximum 20 mA at 10VDC (minimum resistance 600Ω)

Sink:

Voltage Range	0 to 10VDC linear
Sink Current	Maximum 2.5 mA at 1VDC (minimum resistance 4kΩ)

Digital Output (DOT)

General

Output Type 24VAC Triac; software configurable
 Maximum Current 0.5A continuous
 1A @ 15% duty cycle for a 10 minute period
 Power Source, External power supply

0 or 24VAC (On/Off)

Range 0 or 24VAC

PWM

Range Adjustable period from 2 to 65 seconds

Floating

Minimum Pulse On/Off Time 500 milliseconds
 Drive Time Period Adjustable

Digital-Universal Output (DUO)

General

Output Type Universal or digital triac;
 Software configurable

Specifications

Universal Output Mode See Universal Output (UO)
 Digital Output Mode See Digital Output (DOT)

Dimensions

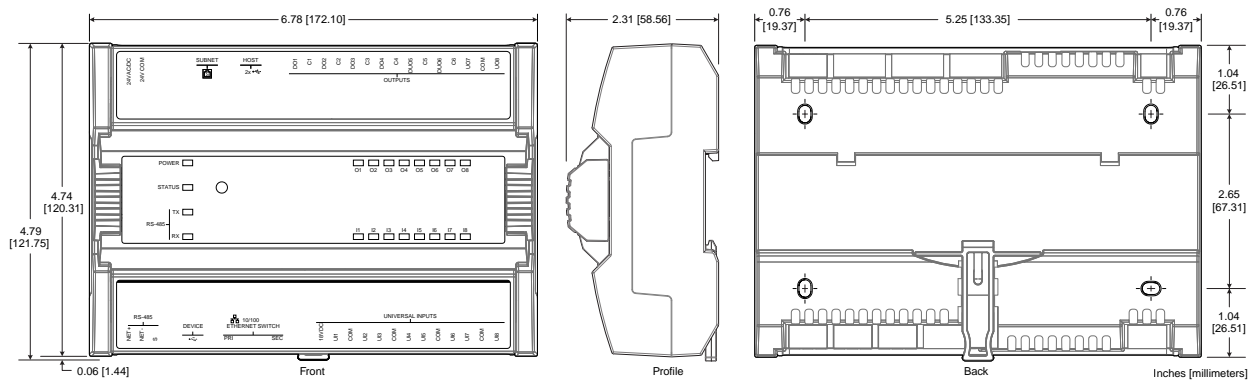

Specifications subject to change without notice.

ECLYPSE, Distech Controls, the Distech Controls logo, EC-Net, Allure, and Allure UNITOUCH are trademarks of Distech Controls Inc. BACnet is a registered trademark of ASHRAE; BTL is a registered trademark of the BACnet Manufacturers Association. The Bluetooth™ word mark and logos are registered trademarks owned by Bluetooth SIG, Inc. and any use of such marks is under license. All other trademarks are property of their respective owners.

©, Distech Controls Inc., 2015 - 2023 All rights reserved.

Global Head Office - 4205 place de Java, Brossard, QC, Canada, J4Y 0C4 - EU Head Office - ZAC de Sacuny, 558 avenue Marcel Mérieux, 69530 Brignais, France

Eclipse™ Connected VAV Controller



The Eclipse Connected VAV Controller (ECY-VAV) is designed to control any variable air volume (VAV) box. It supports BACnet/IP communication and is a listed BACnet Building Controller (B-BC).

The ECY-VAV comes with an embedded web server that enables web-based VAV application configuration and a visualization interface. It also features embedded scheduling, alarming, and logging. Control logic and graphic user interface can be customized as required for the application.

Features & Benefits

- Uses BACnet/IP and IT standards, delivering empowered IP connectivity and open integration with building management systems
- Uses cryptographic modules making it FIPS 140-2 "Inside"
- Via its RESTful API, data can be accessed from different applications, such as energy dashboards, analytics tools, and mobile applications
- Comes with Eclipse Designer Viewer and the associated preloaded rooftop unit applications and graphics pre-installed
- xpressENVYSION offers a simplified and streamlined experience in a workflow oriented, drag & drop GUI environment
- Supports EC-*gfx*Program, which makes Building Automation System (BAS) programming effortless
- Supports DC Space for an end-to-end system for the control of HVAC equipment, lighting, and shades/sunblinds
- Embedded alarms, trend log and schedule support allows for fully distributed data and logic providing a more robust system
- Automatic email notifications for system status and alarms to ensure faster system servicing and response time
- Robust hardware design featuring metallic pitot terminal barbs as well as metallic anchor point and mounting bracket
- Eclipse edge analytics automates the commissioning process, saving up to 30-45 minutes per device

Model Selection

Example: ECY-VAV **(SI)**
 ECY-VAV **(IMP) Plenum-rated**

Series ^a	Model	Units	Option
ECY-VAV	[blank] : Standard 24VAC/DC power supply -PoE : Power Over Ethernet	(SI) : Preloaded Apps in SI (Metric) units (IMP) : Preloaded Apps in Imperial (US) units	Plenum-rated : UL2043 plenum-rated with standard 24VAC/DC power supply (only for North America, not available with PoE model).
11-points, 4 UI, 2 UO, 4 DO, 18 Vdc power supply output, built-in flow sensor, integrated damper actuator, ENVYISION viewer			

^aSEP models (single Ethernet port) have secondary Ethernet port factory disabled

Accessories

Eclipse Wi-Fi Adapter	Wi-Fi Adapter for Eclipse Connected Controllers.
Eclipse Open-To-Wireless™ Adapter	EnOcean communication protocol adapter for Eclipse Connected Controllers.
Terminal covers	Terminal cover designed to conceal the wire terminals of the ECY-VAV Series controllers. Required to meet local safety regulations in certain jurisdictions.

Product Specifications

Power Supply Input (ECY-VAV Models)

Voltage Range ^a	24VAC/DC; ±15%; Class 2
Nominal Power Consumption	7VA; all external loads excluded, no USB peripherals
Full Load Power Consumption	20VA; external 24VAC loads excluded
Frequency Range	50 to 60Hz
Overcurrent Protection	Field replaceable fuse
Fuse Type	3A, fast-acting, 5 × 20mm (GMA-3A)
Power Factor	>90%

^a24VDC does not support DO (triac outputs).

BACnet Profile	BACnet Building Controller (B-BC)
BACnet Listing	BTL (B-BC)
BACnet Interconnectivity	BBMD forwarding capabilities BACnet/SC routing
BACnet Transport Layer	IP, BACnet/SC (Node)
Web Server Protocol	HTML5
Web Server Application Interface	REST API
Wireless Adapter	Optional, USB Port Connection
	Refer to the Eclipse Wi-Fi Adapter Spec Sheet

Subnetwork

Communication	RS-485
Cable Type	Cat 5e, 8 conductor twisted pair
Connector	RJ-45
Connection Topology	Daisy-chain
Maximum number of standard room devices supported per controller combined ^a	4
Allure EC-Smart-Vue Series ^b	4
Allure EC-Smart-Comfort Series	4
Allure EC-Smart-Air Series ^b	4
EC-Multi Sensor	4
ECx-Light-4 / ECx-Light-4D / ECx-Light-4DALI ^a	2
ECx-Blind-4 / ECx-Blind-4LV / ECx-Blind4SMI / ECx-Blind-4SMI-LoVo ^a	2
Maximum number of Bluetooth low energy room devices per controller combined ^c	4

Power Supply Input (ECY-VAV-PoE Models)

Power over Ethernet Link Powered	IEEE 802.3at
PoE Switch	Must be listed as Limited Power Source (LPS) per UL60905
Overcurrent Protection	Field replaceable fuse
Fuse Type	3A, fast-acting, 5 × 20mm (GMA-2A)
Powering External Devices	Up to 15 Watts maximum (power is available from the controller's power supply input terminals)

Communications

Ethernet Connection Speed	10/100 Mbps
Cable Type	Cat 5e, 8 conductor twisted pair (unshielded)
Addressing	IPv4 or Hostname

Allure Unitouch™ 2
 EC-Multi-Sensor-BLE 4

^aFor more details about supported quantities, see the Product Selection Tool available in Builder: <https://builder.distech-controls.com>.

^bA controller can support a maximum of 2 Allure sensor models equipped with a CO₂ sensor. Any remaining connected sensors must be without a CO₂ sensor.

^cA mixed architecture with standard room devices and Bluetooth low energy enabled devices is not recommended.

Hardware

Processor	Sitara ARM processor
CPU Speed	600MHz
Memory	4GB Non-volatile Flash (applications & storage) 512MB RAM
Real Time Clock (RTC)	Real Time Clock with rechargeable battery Supports SNTP network time synchronization
RTC Battery	20 hours charge time, 20 days discharge time Up to 500 charge / discharge cycles
Cryptographic Module	FIPS 140-2 Level 1 Compliant
Ethernet	2 switched RJ-45 Ethernet ports (Supported Protocols: BACnet/IP, Modbus TCP, NTP, and REST)
Ethernet (ECY-VAV-POE)	1 × RJ-45 PoE+ Ethernet port 1 × switched RJ-45 Ethernet port
Integrated fail-safe for daisy-chaining	In case of power failure to one of the controllers, communication data is still relayed to the following controller on the daisy-chain
USB Connections	2 × USB 2.0 Ports 1 × Micro-USB 2.0 Ports
RS-485 Serial Communications	Screw terminals (Supported Protocols: Modbus RTU)
Subnet	RJ-45
Green LED	Power status, Subnet TX, and Ethernet Traffic
Orange LED	Controller status, Subnet RX, and Ethernet Speed

Open-to-Wireless Adapter

Communication Protocol	EnOcean wireless standard ^a
Connector Type	USB
Number of Wireless Inputs	Unlimited ^b



^aAvailable when an optional external Eclipse Open-to-Wireless Adapter is connected to the controller. Refer to the Open-to-Wireless Application Guide for a list of supported EnOcean wireless modules.

^bWireless inputs will only be limited by physical distance between the EnOcean devices and the Eclipse Open-to-Wireless Adapter.

Integrated Damper Actuator

Motor	Belimo brushless DC motor
Torque	45 in-lb, (5 Nm)

Degrees of Rotation	95° adjustable
Shaft Diameter	5/16 to 3/4" (8.5 to 18.2mm)
Acoustic Noise Level	< 35 dB (A) @ 95° rotation in 95 seconds

Mechanical

ECY-VAV Dimensions (H × W × D)	7.90 × 5.51 × 3.70" (200.61 × 139.93 × 94.04 mm)
ECY-VAV-PoE Dimensions (H × W × D)	7.90 × 8.17 × 3.70" (200.61 × 207.59 × 94.04 mm)
Dimensions with Terminal Covers (H × W × D)	7.90 × 10.84 × 3.70" (200.61 × 275.26 × 94.04 mm)
ECY-VAV Shipping Weight	2.00lbs (0.90 kg)
ECY-VAV-PoE Shipping Weight	2.50lbs (1.14 kg)
Terminal Cover Shipping Weight (one side, bulk packaged)	0.30lbs (0.14 kg)
Enclosure Material ^a	FR/ABS
Enclosure Rating	Plastic housing, UL94-5VB flammability rating

^aAll materials and manufacturing processes comply with the RoHS directive and are marked according to the Waste Electrical and Electronic Equipment (WEEE) directive

Environmental

Operating Temperature	32 to 122°F (0 to 50°C)
Storage Temperature	-4 to 122°F (-20 to 50°C)
Relative Humidity	0 to 90% non-condensing
Ingress Protection Rating	IP20 (IEC 60552)
Nema Rating	1

Standards and Regulations

CE Emission	EN61000-6-3: 2007+A1:2011
CE Immunity	EN61000-6-1: 2007
FCC	Compliance with FCC rules part 15, subpart B, class B
UL Listed (CDN & US)	UL916 Energy management equipment UL2043 Suitable for use in air handling spaces (for Plenum-rated models only)



On-Board Air-Flow Sensor

Differential Pressure Range	±2.0 in. W.C. (±500 Pa) Polarity-free high-low sensor connection
Input Resolution	0.00007 in. W.C. (0.0167 Pa)

Eclipse™ Connected VAV Controller

Air Flow Accuracy $\pm 4.0\%$ @ > 0.05 in. W.C. (12.5 Pa)
 $\pm 1.5\%$ once calibrated through air flow balancing @ > 0.05 in. W.C. (12.5 Pa)

Pressure Sensor Accuracy $\pm(0.2 \text{ Pa} + 3\%$ of reading)

Universal Inputs (UI) General

Input Type Universal; software configurable
 Input Resolution 16-bit analog to digital converter
 Power Supply Output 18VDC; 80mA maximum
 Protection Auto-reset fuse for 24VAC protection

Contact

Type Dry contact

Counter

Type Dry contact
 Maximum Frequency 1Hz maximum
 Minimum Duty Cycle 500 ms On / 500 ms Off

0 to 10VDC

Range 0 to 10VDC (40k Ω input impedance)

0 to 5VDC

Range 0 to 5VDC (high input impedance)

0 to 20mA

Range 0 to 20mA, 249 Ω external resistor wired in parallel

Resistance/Thermistor

Range 0 to 350 K Ω
 Supported Thermistor Types Any that operate in this range

Pre-configured Temperature Sensor Types

Thermistor 10K Ω Type 2, 3 (10K Ω @ 77°F; 25°C)
 Platinum Pt1000 (1K Ω @ 32°F; 0°C)
 Nickel RTD Ni1000 (1K Ω @ 32°F; 0°C)
 RTD Ni1000 (1K Ω @ 69.8°F; 21°C)

Universal Outputs (UO) General

Output Type Universal; software configurable
 Output Resolution Converter 10-bit digital to analog Converter
 Output Protection Built-in snubbing diode to protect against back-EMF, for example when used with a 12VDC relay Output is internally protected against short circuits
 Auto-reset Fuse Provides protection from accidental 24VAC connection

0 or 12VDC (On/Off)

Range 0 or 12VDC
 Source Current Maximum 20 mA at 12VDC (minimum resistance 600 Ω)

PWM

Range Adjustable period from 2 to 65 seconds
 Thermal Actuator Management Adjustable warm up and cool down time

Floating

Minimum Pulse On/Off Time 500 milliseconds
 Drive Time Period Adjustable

0 to 10VDC

Source

Voltage Range 0 to 10VDC linear
 Source Current Maximum 20 mA at 10VDC (minimum resistance 600 Ω)

Sink

Voltage Range 0 to 10VDC linear
 Sink Current Maximum 2.5 mA at 1VDC (minimum resistance 4k Ω)^a

^aWhen the VAV is not powered, there is no default sink voltage.

Digital Output (DO) General (ECY-VAV Models)

Output Type 24VAC Triac; software configurable

Maximum Total Current for all Outputs 2A
 Power Source, External or internal (jumper selectable)
 Maximum Current per Output 0.5A continuous
 1A @ 15% duty cycle for a 10 minute period

External Power Source

Voltage 24VAC from external source
 Maximum Current per Output 0.5A continuous
 1A @ 15% duty cycle for a 10 minute period

General (ECY-VAV-PoE Models)

Output Type 24VAC Triac; software configurable
 Power Source External or internal (jumper selectable)

0 or 24VAC (On/Off)

Range 0 or 24VAC

Internal Power Source

Network Switch 802.3at
 Maximum Total Power for all Digital Outputs 15W
 Maximum Current per Output 0.5A continuous, power supply limited
 Waveform 24 VAC square wave

PWM

Range Adjustable period from 2 to 65 seconds

Floating

Minimum Pulse On/Off Time 500 milliseconds
 Drive Time Period Adjustable

Dimensions

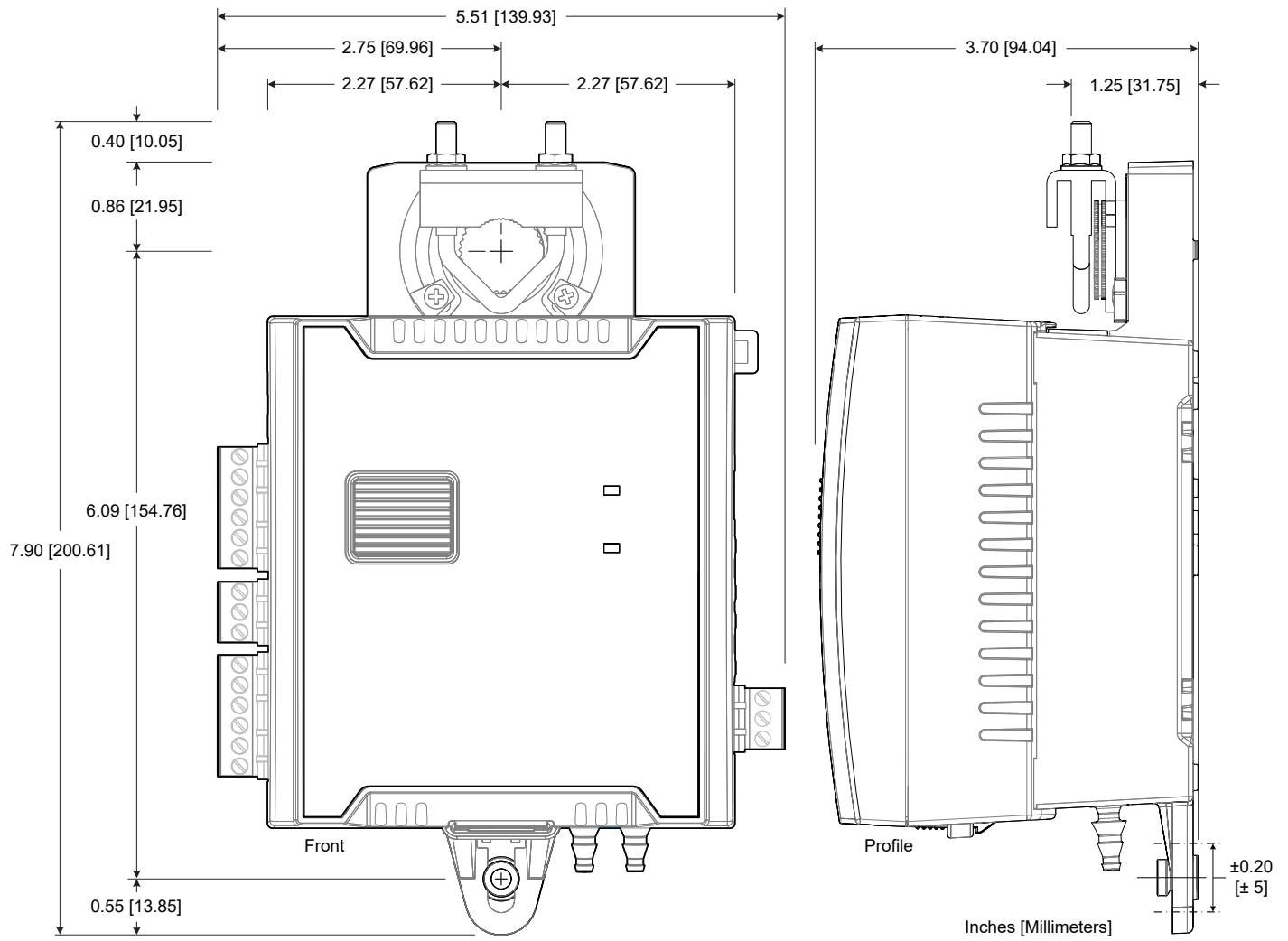

ECY-VAV Controller Dimensions

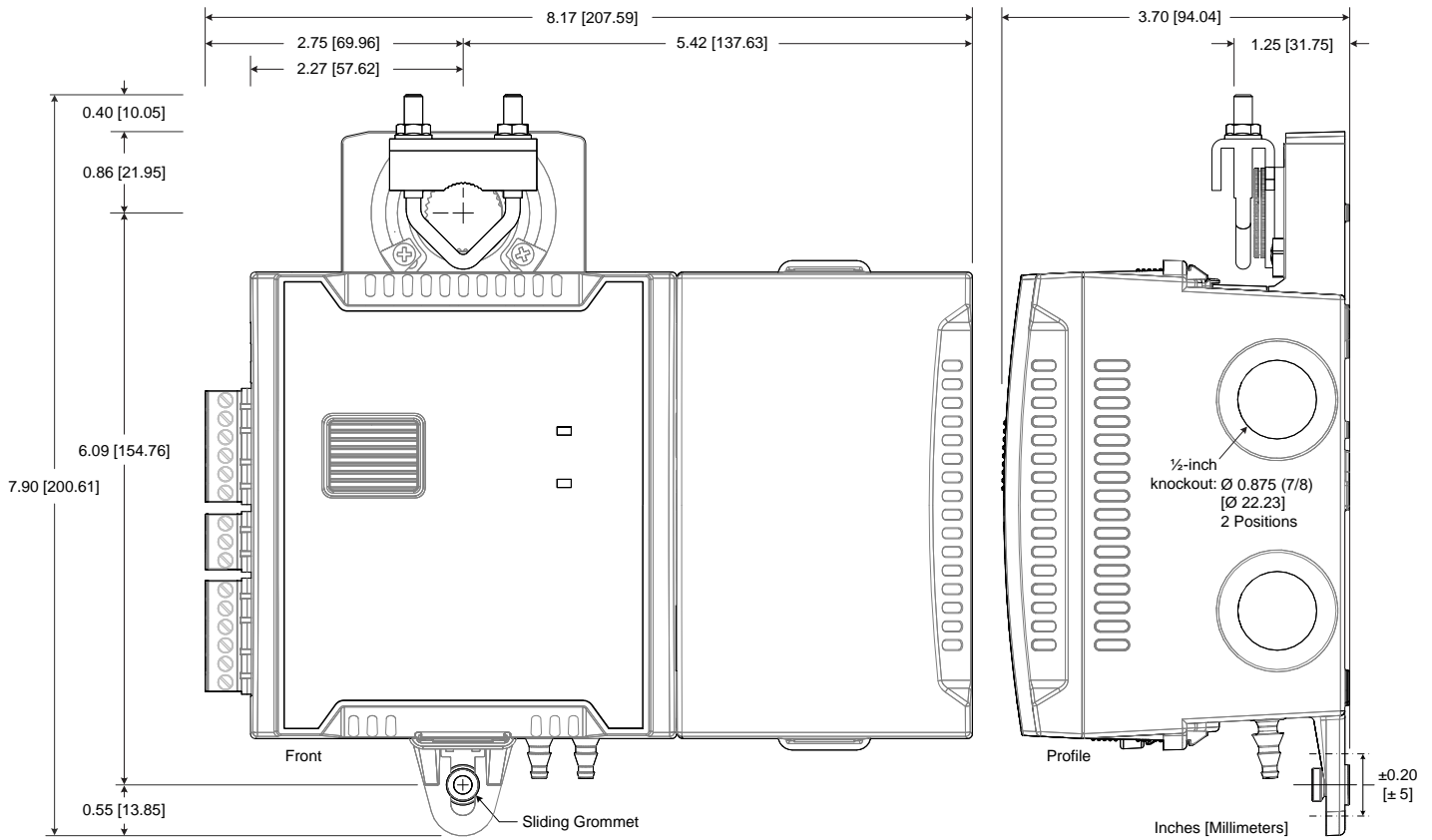

ECY-VAV-PoE Controller Dimensions

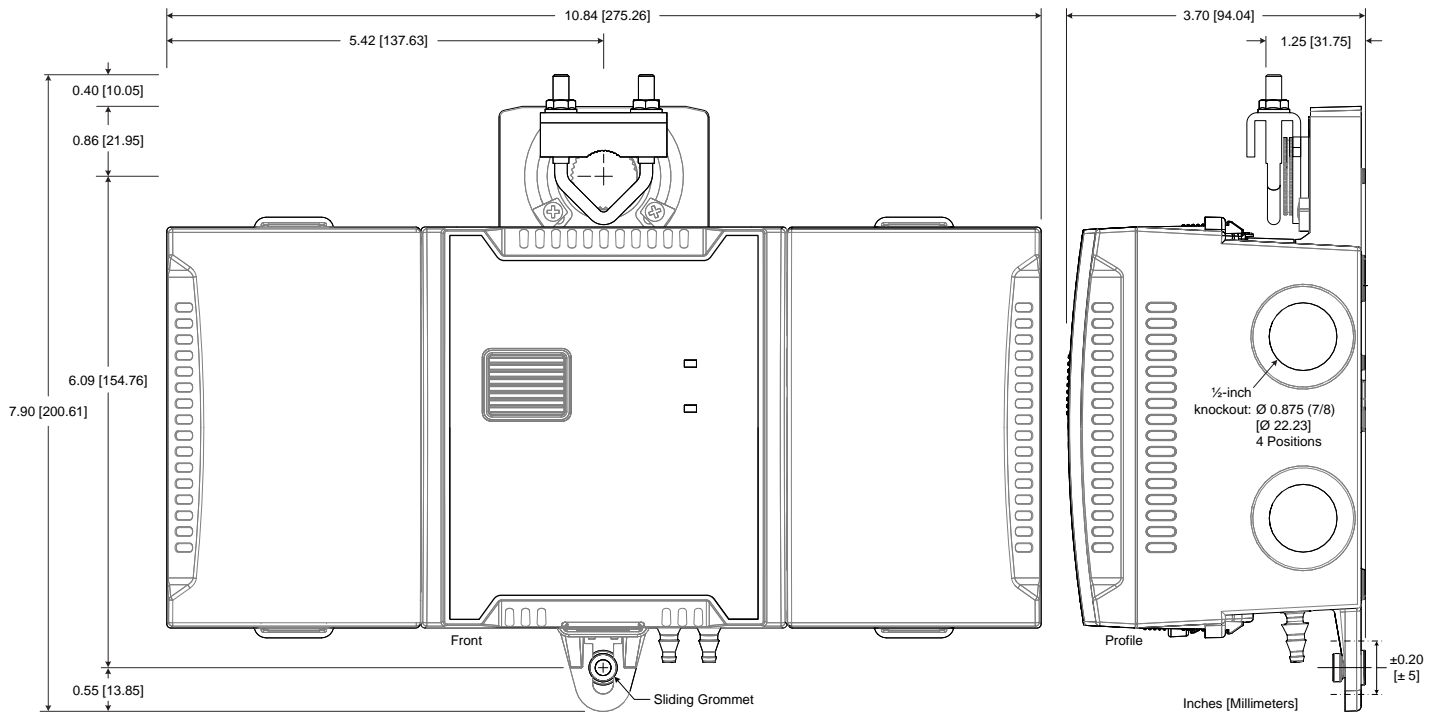

ECY-VAV Controller with Terminal Covers Dimensions

Specifications subject to change without notice.

Eclipse, Distech Controls, the Distech Controls logo, EC-Net, Allure, and Allure UNITOUCH are trademarks of Distech Controls Inc. BACnet is a registered trademark of ASHRAE; BTL is a registered trademark of the BACnet Manufacturers Association. The Bluetooth® word mark and logos are registered trademarks owned by Bluetooth SIG, Inc. and any use of such marks is under license. All other trademarks are property of their respective owners.

©, Distech Controls Inc., 2025 All rights reserved.

Global Head Office - 4205 place de Java, Brossard, QC, Canada, J4Y 0C4 - EU Head Office - ZAC de Sacuny, 558 avenue Marcel Mérieux, 69530 Brignais, France

Allure™ EC-Smart-Comfort Series

Communicating sensors with
Smart-Light and Smart-Blind
add-on modules



Overview

The Allure EC-Smart-Comfort Series are versatile communicating sensors which provide precise temperature sensing.

Tailored for occupants, the Allure EC-Smart-Comfort Series' intuitive design features coloured LED indicators to provide user feedback, rotary knobs to adjust the setpoint offset and fan speed, and a push-button to apply occupancy override.

As a multi-function room device, the Allure EC-Smart-Comfort Series sensor can be expanded with a combination of up to 4 Smart-Light/Blind Series add-on push-button modules, for lighting and shade/sunblind control, making it an ideal all-in-one addition to the Smart Room Control solution.

Features & Benefits

- Compatible with the ECL series LonWorks® Controllers, ECB series BACnet® Controllers and ECLYPSE™ series BACnet/IP and Wi-Fi Controllers, including the Smart Room Control solution.
- Dedicated rotary knobs for setpoint offset and fan speed adjustment, and its override occupancy pushbutton allow occupants to easily adjust comfort parameters
- All models come with an on-board temperature sensor for a precise feedback based temperature control
- Select models feature a push-button occupancy indicator, to allow occupants to override system schedules: occupied, unoccupied or standby mode
- Lighting & shade/sunblind management with the addition of up to 4 clip-on Smart-Light and Smart-Blind add-on modules
- Available with 8 digital inputs for connection to existing or architect-specified light and shade/ sunblind switches, or for use with other room device outputs
- The Allure EC-Smart-Comfort Sensor is wired to the dedicated subnet port on the controller which frees up controller inputs
- Both power and communications pass through a single Cat 5e cable for reduced installation costs and easier installation
- Included quick-link connectors accelerates installation time by up to 75%
- Versatile mounting options including dry wall, or North American, European, Swiss, or Asian style switch box
- Error feedback with EC-gfxProgram enables technicians to troubleshoot problems

Model Selection

Example: Allure EC-Smart-Comfort-SF-DI

Series	Functionality	Digital Inputs
Allure EC-Smart-Comfort-S	[blank]: no Occupancy Management, no Fan Speed O : Occupancy Management F : Fan Speed OF : Occupancy Management, Fan Speed	[blank]: None -DI : 8

Accessories

Smart-Light/Blind modules ¹	Description
Smart-Light-1	Add-on Module for the control of 1 dimmable lighting group
Smart-Light-2	Add-on Module for the control of 2 ON/OFF lighting groups
Smart-Blind	Add-on Module for the control of 1 shade/sunblind group

1. Each Smart-Light/Blind Series add-on module uses 2 digital inputs.

Product Specifications

Power Supply Input

Voltage 16 VDC maximum, Class 2
 Power Consumption At the connected controller, an additional 0.25 VA

Models without digital inputs: 0.331lbs (0.150 kg)
 Enclosure Material ABS
 Enclosure Rating Plastic housing, UL94-V0 flammability rating

Communications

Rate 38 400 bps
 Communications RS-485
 Wiring Cable length: 600 ft (180 m) maximum
 Cable Type T568B Cat 5e network cable, 4 twisted pairs
 Connectors **IN**: RJ-45
OUT: RJ-45 (pass-through for daisy chain connection to other room devices)

Color white
 Installation wall mounting through mounting holes (see figure on next page for hole positions) or switch box (North America / European / Asian / Swiss)

Temperature Sensor

Type 10 kΩ NTC Thermistor
 Range 41°F to 104°F (5°C to 40°C)
 Accuracy ± 0.9°F (± 0.5°C)
 Resolution 0.18°F (0.1°C)

Environmental

Operating Temperature 32°F to 122°F (0°C to 50°C)
 Storage Temperature -4°F to 122°F (-20°C to 50°C)
 Relative Humidity 0 to 90% Non-condensing
 Ingress Protection Rating IP20
 Nema Rating 1

Commands

Temperature setpoint Type: Infinite knob
 Status indicator: 7 configurable LEDs: 3 blue, 1 white, 3 red
 Fan speed selection Type: Infinite knob
 Status indicator: 5 configurable LEDs: Auto, Off, I, II, III
 Occupancy management Type: Push-button
 Status indicator: 1 programmable LED

Standards and regulations

CE Emission EN 61000-6-3: 2007 + A1: ed.2011
 CE Immunity EN 61000-6-1: 2007
 FCC FCC rules part 15, subpart B class B
 UL Listed (CDN & US) UL 916 Energy Management Equipment
 CSA C22.2 No. 205-12
 File number: E228719
 RoHS All materials and manufacturing processes comply with the RoHS directive.
 WEEE All products are marked according to the Waste Electrical and Electronic Equipment (WEEE) directive.

Mechanical

Allure EC-Smart-Comfort Series Dimensions (H × W × D) 4.60 × 3.30 × 1.30" (117 × 84 × 33 mm)
 Smart-Light/Blind Series Dimensions (H × W × D) 0.90 × 3.30 × 0.98" (23 × 84 × 25 mm)
 Shipping Weight Models with digital inputs: 0.428lbs (0.194 kg)



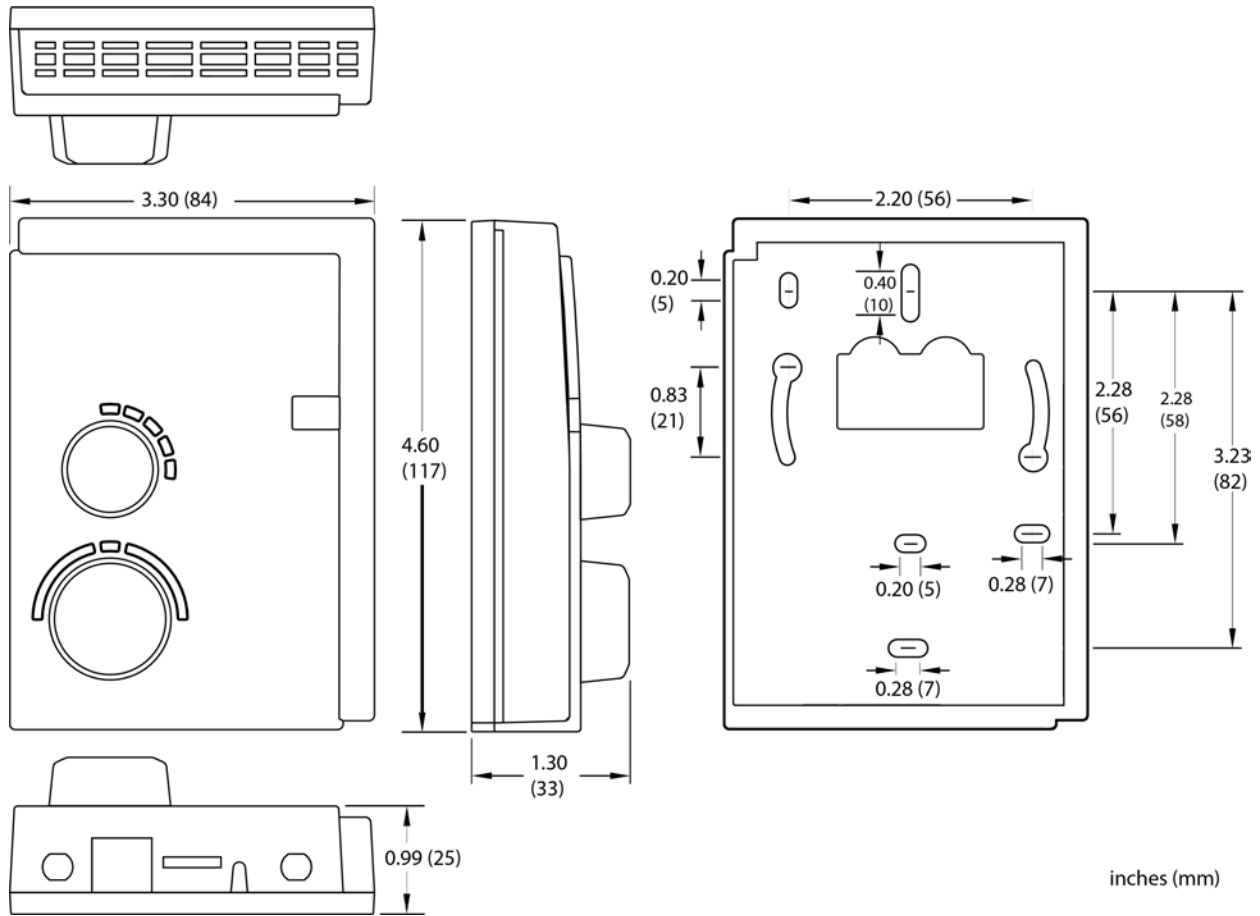

Smart Light/Blind modules

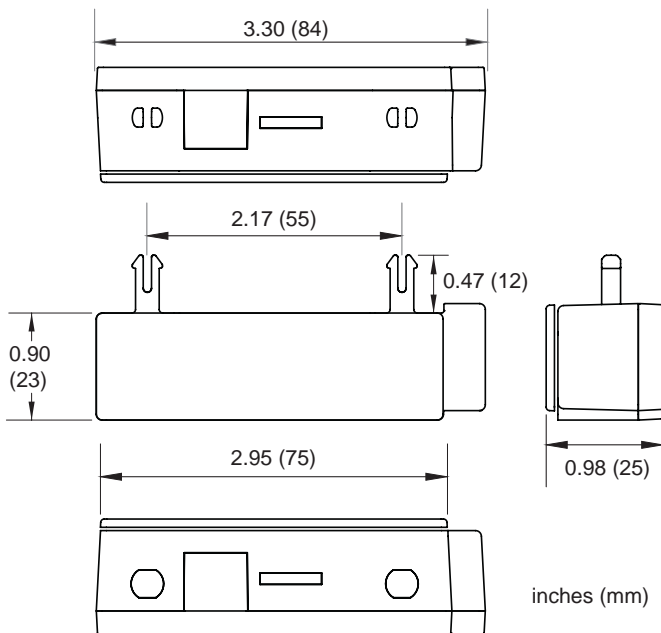

inches (mm)

Specifications subject to change without notice.

ECLYPSE, Distech Controls, the Distech Controls logo, EC-Net, Allure, and Allure UNITOUCH are trademarks of Distech Controls Inc. BACnet is a registered trademark of ASHRAE; BTL is a registered trademark of the BACnet Manufacturers Association. The Bluetooth™ word mark and logos are registered trademarks owned by Bluetooth SIG, Inc. and any use of such marks is under license. All other trademarks are property of their respective owners.

©, Distech Controls Inc., 2015 - 2022 All rights reserved.

Global Head Office - 4205 place de Java, Brossard, QC, Canada, J4Y 0C4 - EU Head Office - ZAC de Sacuny, 558 avenue Marcel Mérieux, 69530 Brignais, France

VAV Discharge Air Temp Sensor



Model TE-701-BX

RoHS



- Designed for VAV discharge air temperature sensing. Comes with 12 feet of plenum rated cable and 1/4" quick disconnects for ease of installation to any VAV controller.
- 304 SS thin wall probe with a cold rolled hermetically sealed end forms a monolithic encapsulation cavity for the sensor and is immune to failures caused by high humidity, contamination, thermal shock and vibration.
- The flat probe end provides a large thermally sensitive area and the sensor is in direct thermal contact to this surface. As a result, extremely fast response is achieved to changes in temperature.
- Probe is crimped to the flange using a patented process to provide a rugged, reliable and low profile attachment for ease of installation.
- More than 15 types of interchangeable NTC thermistors, precision platinum, nickel or balco RTDs are available for universal compatibility.

TE-701-BX is an enhanced version of the popular TE-701-B duct temperature sensor. Plenum rated cable has been extended to 12 feet and 1/4" quick disconnects have been added to customize the sensor for VAV applications and to provide a low cost, labor saving solution for most of the VAV controllers in the industry. The sensor is available in 4 or 6 inch probe length to accommodate any size discharge air duct. For additional specifications please refer to the TE-701/702 data sheet.



8189 Century Blvd. • Minneapolis, MN 55317-8002 • USA
800-843-5116 • 952-556-4900 • Fax 952-556-4997
sales@mamacsys.com • www.mamacsys.com

Baird House, Units 6&7
Pensnett Estate • Kingswinford
West Midlands • DY6 7YA • United Kingdom
01384-271113 • Fax 01384-271114

4 Arminger Court, Unit 2
Holden Hill • S.A. 5088 • Australia
08-8395-4333 • Fax 08-8395-4433

155 McIntosh Drive, Units 5&6 • Markham
Ontario • L3R 0N6 • Canada
905-474-9215 • Fax 905-474-0876

No. 22 Lorong 21A Geylang # 11-02
Prosper Industrial Building
Singapore • 388421
656-3927273 • Fax 656-3927276

TE-701-BX

SPECIFICATIONS:

Platinum RTD sensors:	+/- 0.1% @ 0 C, Alpha : 385 per DIN 43760
Nickel RTD sensors: (#2)	+/- 0.5 C @ 0 C, 5000 PPM/K T.C.R.
Nickel RTD sensors: (#4)	+/- 0.5 F @ 70 F / 21.1 C, 6000 PPM/K T.C.R.
Balco RTD sensors:	+/- 0.5 F @ 70 F / 21.1 C, 4300 PPM/K T.C.R.
Thermistor sensors:	+/- 0.2 C interchangeability @ 77 F / 0 C
Probe Material:	1/4" / 6.3 mm O.D, 0.020" / 0.5 mm wall 304 Stainless Steel
Flange Material:	Galvanized Steel
Operating Temp:	-40F/-40C to 210F/100C
Ambient Temp:	-40F/-40C to 160F/70C
Warranty:	Five Years (Lifetime on Moisture Migration)

Covered under: U.S. PATENT NO. 6457857, 7036224

ORDERING INFORMATION: TE-701-BX

Sensor*	Probe Length
1 100 ohm Platinum RTD	A 4 inches/100mm
2 1,000 ohm Nickel RTD (5000 PPM)	B 6 inches/150mm
3 1,000 ohm Platinum RTD	
4 1,000 ohm Nickel RTD (6000 PPM)	
5 1,000 ohm Balco RTD	
7 10,000 ohm NTC thermistor (Type III)	
8 10,000 ohm NTC thermistor (Carel)	
10 3,000 ohm NTC thermistor	
12 10,000 ohm NTC thermistor (Type II)	
13 5,000 ohm NTC thermistor	
14 1,035 ohm Silicon PTC	
15 100,000 ohm NTC thermistor	
17 20,000 ohm NTC thermistor	
18 2,252 ohm NTC thermistor	
21 1,800 ohm NTC thermistor	

Example: TE-701-BX-12-A: VAV Discharge Air Temp Sensor with 10,000 ohm NTC thermistor (Type II) and 4 inch probe length.

* For sensor compatibility, please refer to TI.700-10.

** For a complete Resistance vs. Temperature tables, please refer to TI.700-11.

*** For additional information including dimensional drawings, please refer to DN701/2.2.



8189 Century Blvd. • Minneapolis, MN 55317-8002 • USA
800-843-5116 • 952-556-4900 • Fax 952-556-4997
sales@mamacsys.com • www.mamacsys.com

Baird House, Units 6&7
Pensnett Estate • Kingswinford
West Midlands • DY6 7YA • United Kingdom
01384-271113 • Fax 01384-271114

4 Arminger Court, Unit 2
Holden Hill • S.A. 5088 • Australia
08-8395-4333 • Fax 08-8395-4433

155 McIntosh Drive, Units 5&6 • Markham
Ontario • L3R 0N6 • Canada
905-474-9215 • Fax 905-474-0876

No. 22 Lorong 21A Geylang # 11-02
Prosper Industrial Building
Singapore • 388421
656-3927273 • Fax 656-3927276

Outdoor Air Temperature Sensor



Model TE-706-B

RoHS

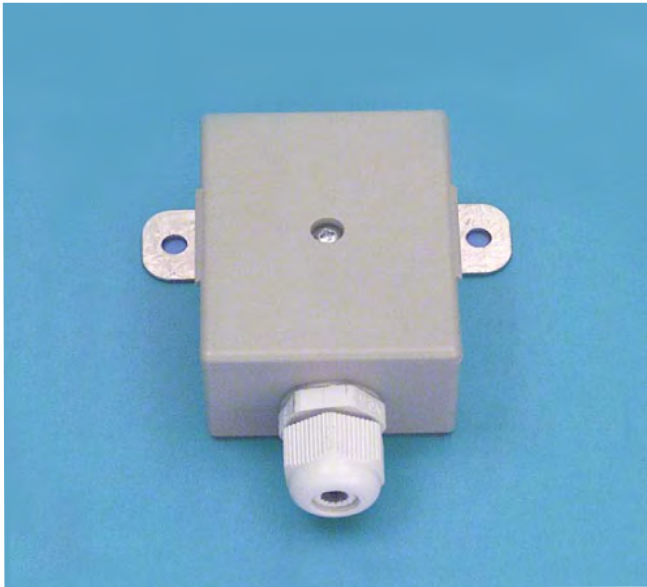

- Rugged, corrosion free 30% glass fill polycarbonate enclosure rated NEMA-4 (IP65)
- Liquid tight connector to ensure moisture proof operation
- External mounting bracket and single screw cover attachment provide a low cost, quick and easy installation
- More than 16 types of interchangeable NTC thermistors, precision platinum, nickel or balco RTDs are available for universal compatibility
- Conforms to EMC and RoHS standards

The TE-706-B outdoor air temperature sensor meets the rigorous requirements of building owners and control professionals who need reliable outdoor air temperature data. This rugged, reliable outdoor air sensor incorporates more than thirty plus years of product development and experience drawn from millions of installations world wide in all types of climatological situations. The corrosion free 30% glass filled polycarbonate enclosure is designed to withstand temperature extremes, mechanical shock and vibration. The external mounting bracket crimp on to the enclosure for a low profile mating surface and the single screw cover attachment, are some of the features which improve reliability and lower installation cost. The TE-706-B features the well-known MAMAC Systems temperature sensor, carefully sealed in the polycarbonate enclosure via a cable gland to prevent building air from escaping across the sensor. This product and process design combined with automated manufacturing processes yields a rugged, reliable, repeatable and stable temperature sensor at a low cost.



8189 Century Boulevard • Minneapolis, MN 55317-8002 • USA
800-843-5116 • 952-556-4900 • Fax 952-556-4997
sales@mamacsys.com • www.mamacsys.com

4200 Waterside Centre
Solihull Parkway
Birmingham • West Midlands
B37 7YN • United Kingdom
01384-271113 • Fax 01384-271114

1 Fullerton Road #02-01
One Fullerton
Singapore • 049213
65-31581826 • Fax 65-31581826

4 Armiger Court, Unit 2
Adelaide • S.A.
5088 • Australia
08-8395-4333 • Fax 08-8395-4433

675 Cochrane Drive
East Tower • 6th Floor
Toronto • Ontario
L3R 0B8 • Canada
905-474-9215 • Fax 905-474-0876

TE-706-B

SPECIFICATIONS:

Platinum RTD sensors:	+/- 0.1% @ 0 C, Alpha : 385 per DIN 43760
Nickel RTD sensors: (#2)	+/- 0.5 C @ 0 C, 5000 PPM/K T.C.R.
Nickel RTD sensors: (#4)	+/- 0.5 F @ 70 F / 21.1 C, 6000 PPM/K T.C.R.
Balco RTD sensors:	+/- 0.5 F @ 70 F /21.1 C, 4300 PPM/K T.C.R.
Thermistor sensors:	+/- 0.2 C interchangeability @ 77 F/ 25 C
Plastic Enclosure:	Polycarbonate 30% glass filled, rated UL 94V-5-0
Operating Temp:	-40F/-40C to 210F/100C
Ambient Temp:	-40F/-40C to 160F/70C
Weight:	2.4 oz (4.6 g)

CONFORMANCE & TESTING:

RoHS Compliant

EMC Testing:

BS EN 55022:1998, BS EN 55024:1998,
EN 61000-3-3, EN 61000-4-2,
EN 61000-4-3, EN 61000-4-4,
EN 61000-4-5, EN 61000-4-6,
EN 61000-4-11

ORDERING INFORMATION: TE-706-B-

Temperature Sensor	
--------------------	--

1	100 ohm Platinum RTD
2	1,000 ohm Nickel RTD (5000 PPM)
3	1,000 ohm Platinum RTD
4	1,000 ohm Nickel RTD (6000 PPM)
5	1,000 ohm Balco RTD
7	10,000 ohm NTC thermistor (Type III)
8	10,000 ohm NTC thermistor (Carel)
10	3,000 ohm NTC thermistor
12	10,000 ohm NTC thermistor (Type II)
13	5,000 ohm NTC thermistor
14	1,035 ohm Silicon PTC
15	100,000 ohm NTC thermistor
16	10,000 ohm NTC thermistor (Eliwell)
17	20,000 ohm NTC thermistor
18	2,252 ohm NTC thermistor
21	1,800 ohm NTC thermistor

Example: TE-706-B-3:

Outdoor Air Sensor with 1,000 ohm platinum RTD

* For sensor compatibility, please refer to TI.700-10.

** For complete **Resistance vs. Temperature** tables, please refer to TI. 700-11.

CAUTION: Do not use in explosive/hazardous environment or with flammable/combustible media.

TE-706-B

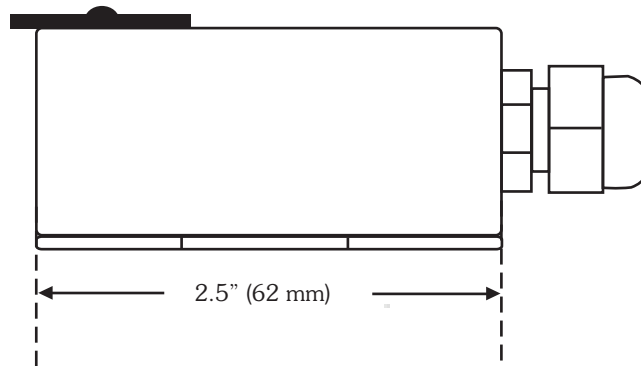
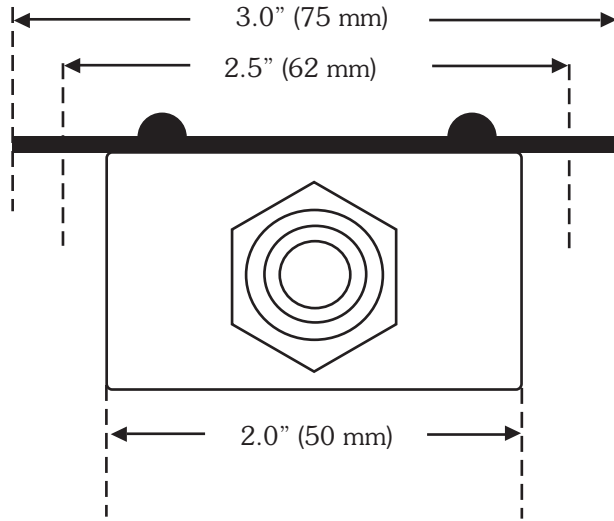

TE-706-B

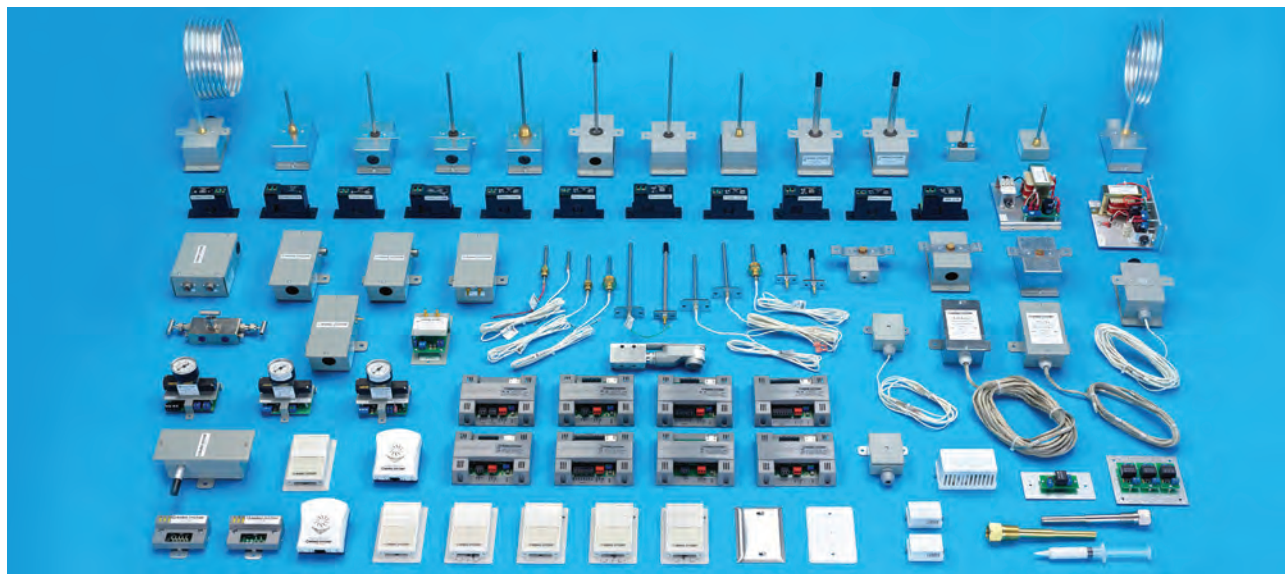

MAMAC Systems is the leading global manufacturer of sensors, transducers, control peripherals and web browser based IP appliances. MAMAC products are used for HVAC and environmental controls, remote monitoring, alarming, energy metering and industrial automation.

All MAMAC products are manufactured in the USA.

WARRANTY: MAMAC Systems, Inc. and its subsidiaries (hereinafter referred to as MAMAC Systems) warrants its products to be free of defects in material and workmanship for a period of five (5) years from date of shipment. If a unit is malfunctioning, it must be returned to the factory for evaluation. A return authorization number (RMA) will be issued by the customer service department and this number must be written or prominently displayed on the shipping boxes and all related documents. The defective part should be shipped freight pre-paid to the factory. Upon examination by MAMAC Systems, if the unit is found to be defective, it will be repaired or replaced at no charge to the customer. However, this warranty is void if the unit shows evidence of being tampered with, damaged during installation, misapplied, misused, or used in any other operating condition outside of the unit's published specifications.

MAMAC Systems makes no other warranties or representations of any kind whatsoever, expressed or implied, except that of title. All implied warranties including any warranty of merchantability and fitness for a particular purpose are hereby disclaimed. User is responsible to determine suitability for intended use.

LIMITATIONS OF LIABILITY: The remedies of buyer set forth herein are exclusive and the total liability of MAMAC Systems with respect to this order, whether based on contract, warranty, negligence, indemnification, strict liability or otherwise, shall not exceed the purchase price of the product upon which liability is based. **In no event shall MAMAC Systems be liable for consequential, incidental or special damages.** MAMAC Systems reserves the right to change any specifications without notice to improve performance, reliability, or function of our products.

Every precaution for accuracy has been taken in the preparation of this manual, however, MAMAC Systems neither assumes responsibility for any omissions or errors that may appear nor assumes liability for any damages that result from the use of the product in accordance with the information contained in the manual.



8189 Century Boulevard • Minneapolis, MN 55317-8002 • USA
800-843-5116 • 952-556-4900 • Fax 952-556-4997
sales@mamacsys.com • www.mamacsys.com

4200 Waterside Centre
Solihull Parkway
Birmingham • West Midlands
B37 7YN • United Kingdom
01384-271113 • Fax 01384-271114

1 Fullerton Road #02-01
One Fullerton
Singapore • 049213
65-31581826 • Fax 65-31581826

4 Armiger Court, Unit 2
Adelaide • S.A.
5088 • Australia
08-8395-4333 • Fax 08-8395-4433

675 Cochrane Drive
East Tower • 6th Floor
Toronto • Ontario
L3R 0B8 • Canada
905-474-9215 • Fax 905-474-0876



MODERN ENERGY SYSTEMS, INC.

P.O. BOX 2030 PALATINE, ILLINOIS 60078-2030 PHONE 773-818-3016 FAX 847-991-0248

ATTENTION: Mr. B Roche	DATE 3/16/2026
PROPOSAL SUBMITTED TO Village of Villa Park	JOB NAME Villa Park Police Department
STREET 20 S Ardmore Ave	JOB LOCATION 40 S Ardmore Ave.
CITY, STATE AND ZIP CODE Villa Park, Illinois 60181	CITY, STATE AND ZIP CODE Same
PHONE	PHONE

Modern Energy Systems, Inc, is pleased to provide you with a quote for the above referenced project, including:

- Remove existing Building Automation controls as discussed. (Honeywell and Staefa contols)
- Furnish a new building automation control system as manufactured by Distech Eclypse controls.
- Install and provide wiring for the Distech Eclypse control system to include
 - Main system controller with communication module and server.
 - Controllers for VAV boxes
 - Sensors for Vav boxes, including OA Sensor
 - Controller for boiler room
 - Controller for for rooftop unit
 - All necessary thermostats, switches, programming
 - All necessary control interlock wiring and cables.

We do not include: permits, bonds, fees, overtime.

This Proposal may be withdrawn by us if not accepted within 30 days.

Terms: 50% Deposit required to order equipment, 25% upon delivery of equipment, balance due upon completion.. 2% per month added to all accounts after 30 days.

We Propose: To furnish necessary material and labor - complete in accordance with the above specifications, for the sum of not to exceed:

Forty Nine Thousand Eight Hundred Sixty dollars \$ **49,860.00**

All material is quaranteed to be as specified. All work to be completed in a workmanlike manner according to standard practices. Any alteration or deviation from the above specifications involving extra costs will be executed only upon written orders, and will become an extra charge over and above the estimate. All agreements contingent upon strikes, accidents or delays beyond our control. Owner to carry fire, tornado and other necessary insurance. Our workers are fully covered by Workmen's Compensation Insurance.

Acceptance of Proposal - The above prices, specifications and conditions are satisfactory and are hereby accepted. You are authorized to do the work as specified. Payment will be made as outlined above.



MEMORANDUM

TO: Village Board of Trustees
FROM: Rich Salerno
DATE: April 13, 2026
SUBJECT: Resolution of the Village of Villa Park, DuPage County, Illinois, for Construction on State Highways

RECOMMENDED ACTION:

A state highway permit must be obtained before starting any construction work on state rights-of-way. State highway permits also require that a surety bond be obtained for each permit, or, in the case of municipalities, that a blanket resolution be approved guaranteeing that the work and restoration will be performed properly.

BACKGROUND:

A state highway permit must be obtained from the Illinois Department of Transportation before starting any construction work on state rights-of-way. In order to obtain a state highway permit, surety bonds are required to be obtained and submitted with each permit application. These surety bonds ensure that all work is completed in accordance with state specifications and that the state right-of-way is properly restored.

If the work under a state highway permit is performed by employees of a municipality rather than by employees of a contractor, a blanket resolution from the municipality covering a period of time of up to two years is acceptable in lieu of the surety bond. This option can greatly expedite the issuance of a state highway permit for emergency repairs, as surety bonds can take several business days to secure. Contractors hired by the municipality must still conform to the normal bonding requirements, in addition to obtaining permits.

The village has utilities on Illinois State Route 38 (Roosevelt Road), Illinois State Route 64 (North Avenue) and Illinois State Route 83 (Kingery Highway). The village's Public Works Department occasionally finds it necessary to perform construction work on the utilities located in these state rights-of-way. This occasional work includes emergency repairs to village-owned water mains and sanitary sewers. It is beneficial to the village, both in terms of the speed with which repairs can be started, and the cost of completing those repairs, to adopt a resolution in lieu of obtaining a surety bond for each repair.

DISCUSSION:

Staff requests approval of a resolution for construction on state highways in lieu of obtaining a surety bond for each state highway permit.

RESOLUTION NO. _____

RESOLUTION OF THE VILLAGE OF VILLA PARK, DUPAGE COUNTY, ILLINOIS, FOR CONSTRUCTION ON STATE HIGHWAYS

WHEREAS, the Village of Villa Park is a municipal corporation duly organized and existing under the laws of the State of Illinois; and

WHEREAS, Chapter 121 of the Illinois Compiled Statutes requires that any person, firm, or corporation desiring to perform construction activities on state-maintained rights-of-way must obtain a written permit from the Illinois Department of Transportation, including any emergency work on broken water mains or sewers; and

WHEREAS, the Illinois Department of Transportation allows municipalities to file a certified resolution in lieu of a surety bond for permit work to be performed by municipal employees; and

WHEREAS, the Village of Villa Park, DuPage County, Illinois, desires to undertake, in the years 2026 and 2027, the location, construction, operation, and maintenance of driveways and street returns, water mains, sanitary and storm sewers, street lights, traffic signals, sidewalks, landscaping, etc., on State Highways within the Village of Villa Park, which by law and/or agreement come under the jurisdiction and control of the Department of Transportation of the State of Illinois (hereinafter referred to as the “Department”); and

WHEREAS, an individual working permit must be obtained from the Department prior to any of the aforesaid installations being constructed either by the Village of Villa Park or by a private person or firm under contract and supervision of the Village of Villa Park; and

WHEREAS, the corporate authorities of the Village of Villa Park find that it is in the best interest of the health, welfare, and safety of the citizens of the Village of Villa Park to adopt a resolution in lieu of a surety bond to ensure that all work is completed following State specifications and that the right-of-way is properly restored.

NOW, THEREFORE, BE IT RESOLVED, by the President and Board of Trustees of the Village of Villa Park, DuPage County, Illinois, as follows:

SECTION 1. That the provisions of the preambles hereinabove set forth are hereby incorporated as if fully set forth herein.

SECTION 2. That the Village of Villa Park hereby pledges its good faith and guarantees that all work shall be performed per the conditions of the permit to be granted by the Department and to hold the State of Illinois harmless during the prosecution of such work, and assume all liability for

damages to persons or property due to accidents or otherwise by reason of the work which is to be performed under the provision of said permit.

SECTION 3. That all authorized officials of the Village of Villa Park are hereby instructed and authorized to sign said working permit on behalf of the Village of Villa Park as the Department requires.

SECTION 4. That the Village Manager is directed to forward a certified copy of this resolution to the District Permit Engineer of the Department.

SECTION 5. The officials, officers, employees, and attorneys of the Village are hereby authorized to take such further actions as are necessary to carry out the intent and purpose of this Resolution and the Agreement.

SECTION 6. All work performed pursuant to this Resolution shall comply with applicable federal, state, and local laws, regulations, and Village codes.

SECTION 7. If any section, paragraph, or provision of this Resolution shall be held to be invalid or unenforceable, the invalidity thereof shall not affect any of the other provisions of this Resolution.

SECTION 8. All ordinances, resolutions, motions or orders in conflict with this Resolution are hereby repealed to the extent of such conflict.

SECTION 9. This resolution shall be in full force and effect from and after its passage and approval as provided by law.

PASSED THIS ____ day of _____, 2026.

AYES:

NAYS:

ABSENT:

APPROVED THIS ____ day of _____, 2026.

ATTEST:

VILLAGE PRESIDENT

VILLAGE CLERK

RESOLUTION NO. _____

A RESOLUTION OF THE VILLAGE OF VILLA PARK, DUPAGE COUNTY, ILLINOIS, APPROVING A TEMPORARY COMMEMORATIVE FLAG IN HONOR OF THE 250TH ANNIVERSARY OF THE SIGNING OF THE DECLARATION OF INDEPENDENCE

WHEREAS, the Village of Villa Park (the “*Village*”) is a duly organized and validly existing non-home rule municipality created in accordance with the Constitution of the State of Illinois of 1970 and the laws of the State; and

WHEREAS, the year 2026 marks the 250th anniversary of the signing of the Declaration of Independence of the United States; and

WHEREAS, the Village desires to recognize and commemorate this historic occasion through participation in the national observance of the Semiquincentennial; and

WHEREAS, the Village has caused to be prepared a commemorative flag design (the “*Commemorative Flag*”), which reflects the significance of the 250th anniversary of the signing of the Declaration of Independence and promotes civic pride within the community, while incorporating elements of the Village’s current flag; and

WHEREAS, a copy of the Commemorative Flag design is attached hereto and incorporated herein as Exhibit A; and

WHEREAS, the President and Board of Trustees of the Village of Villa Park have determined that the temporary display of the Commemorative Flag at Village-owned properties and facilities serves a public purpose by promoting historical awareness and community engagement; and

NOW THEREFORE, BE IT RESOLVED by the President and Board of Trustees of the Village of Villa Park, DuPage County, State of Illinois, as follows:

Section 1: Incorporation of Preambles. The facts and statements contained in the preambles to this Resolution are found to be true and correct and are hereby adopted as part of this Resolution.

Resolution No. _____

Section 2: Approval of Commemorative Flag. The Commemorative Flag attached hereto as Exhibit A is hereby approved as the temporary commemorative flag of the Village of Villa Park.

Section 3: Authorization for Display. The Village Manager is hereby authorized to cause the Commemorative Flag to be produced and displayed at Village-owned properties and facilities in a manner consistent with applicable flag protocols.

Section 4: Duration. The Commemorative Flag approved herein shall be authorized for display through December 31, 2026, unless otherwise extended or terminated by action of the President and Board of Trustees.

Section 5: Non-Codification. This Resolution is intended to be a temporary and ceremonial measure and shall not be codified in the Village Code.

Section 6: Invalidity. If any section, paragraph, clause or provision of this Resolution shall be held invalid, the invalidity thereof shall not affect any of the other provisions of this Resolution.

Section 7: Repealer. All ordinances, resolutions, motions or orders in conflict with this Resolution are hereby repealed to the extent of such conflict.

Section 8: Effective Date. This Resolution shall take effect upon its passage and approval in pamphlet form.

Resolution No. _____

ADOPTED THIS ____ DAY OF _____, 2026, pursuant to a roll call vote as follows:

AYES: _____

NAYS: _____

ABSENT: _____

ABSTENTION: _____

APPROVED this ____ day of _____, 2026

Kevin Patrick, President of the
Village of Villa Park, DuPage County, Illinois

ATTESTED and filed in my office,
this ____ day of _____, 2026

Rolf Laukant, Clerk of the Village
of Villa Park, DuPage County, Illinois

Resolution No. _____

EXHIBIT A
Commemorative Flag Design





MEMORANDUM

TO: Village Board of Trustees

FROM:

DATE: April 13, 2026

SUBJECT: Pursuant to 5 ILCS 120/2(c)(1), the appointment, employment, compensation, discipline, performance, or dismissal of specific employees of the public body or legal counsel for the public body.

RECOMMENDED ACTION:

BACKGROUND:

DISCUSSION: